

Customer Information Sheet

DRAWING No.: M20-877XXXXR

SHEET 3 OF 4

IF IN DOUBT - ASK

©

NOT TO SCALE

THIRD ANGLE PROJECTION

ALL DIMENSIONS IN mm

RECOMMENDED PAD LAYOUT
(TOLERANCE = ± 0.05)

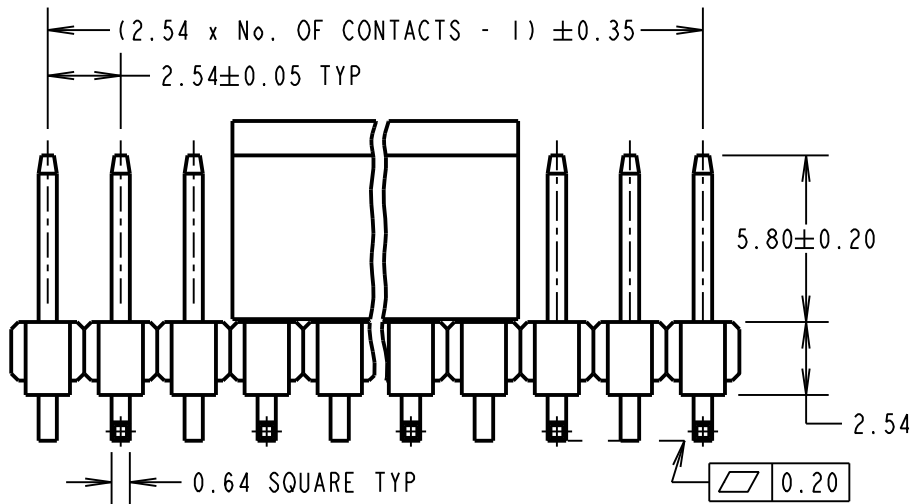
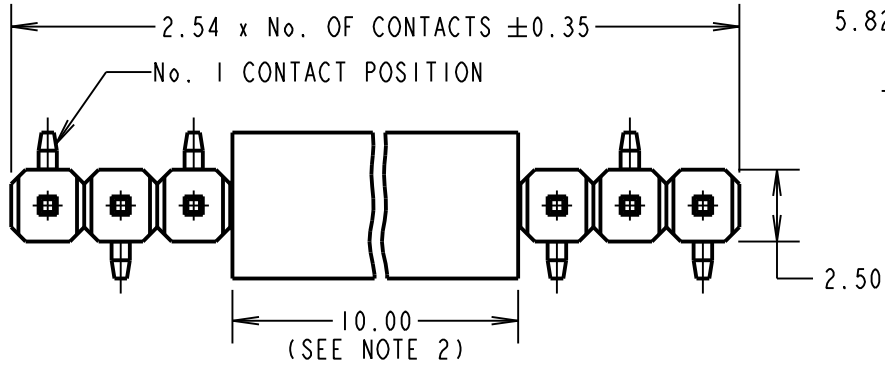
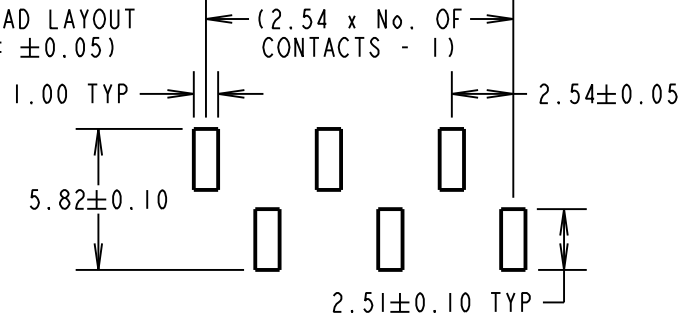

CONTACT TO CONTACT

ORDER CODE:

M20-877XXXXR

No. OF CONTACTS:

02, 03, 04, 06,
08, 10, 15, 19, 28

FINISH:

42 = SELECTIVE GOLD + 100% TIN
46 = 100% TIN

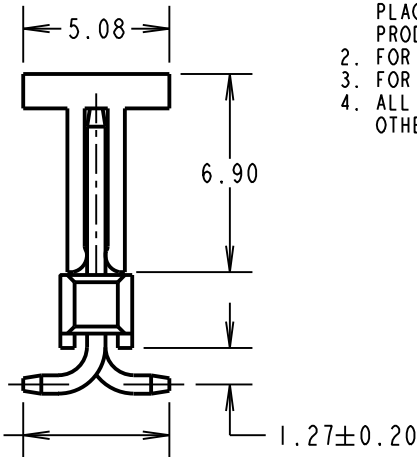

SPECIFICATION:

MATERIAL:

MOULDING = NYLON 6T UL94V-0, BLACK
CONTACT = BRASS

FINISH:

42 = SELECTIVE GOLD ON CONTACT AREA,
100% TIN ON TAILS

46 = 100% TIN

ELECTRICAL:

CURRENT RATING = 3A MAX

CONTACT RESISTANCE = 30 mΩ MAX (TIN),
25 mΩ MAX (GOLD)

INSULATION RESISTANCE = 1,000MΩ MIN

DIELECTRIC STRENGTH = 750V AC/DC

MECHANICAL:

DURABILITY = 50 OPERATIONS (TIN),
300 OPERATIONS (GOLD)

ENVIRONMENTAL:

TEMPERATURE RANGE = -40°C TO +105°C

PACKING:

BAG

FOR COMPLETE SPECIFICATION, SEE COMPONENT
SPECIFICATION C001XX (LATEST ISSUE)

NOTES:

- SEE DRAWING M20-877XXXXP FOR PICK AND PLACE VERSION, M20-877XXXX FOR STANDARD PRODUCT.
- FOR 4 WAYS AND LESS, CAP LENGTH = 6.00mm.
- FOR REELING DETAILS SEE SHEET 4.
- ALL TOLERANCES ARE ± 0.15 mm UNLESS OTHERWISE STATED.

SB	17	05.03.15	12764
NAME	ISS.	DATE	C/NOTE
APPROVED:		S.BENNETT	
CHECKED:		M.PLESTED	
DRAWN:		J. KEIR	
CUSTOMER REF.:			
ASSEMBLY DRG:			

HARWIN

www.harwin.com
technical@harwin.com

THIS DRAWING AND ANY INFORMATION OR DESCRIPTIVE MATTER SET OUT HEREON ARE CONFIDENTIAL AND COPYRIGHT PROPERTY OF THE HARWIN GROUP AND MUST NOT BE DISCLOSED, LOANED, COPIED OR USED FOR MANUFACTURING, TENDERING OR FOR ANY OTHER PURPOSE WITHOUT THEIR WRITTEN PERMISSION.

TOLERANCES

X = ± 1 mm
X.X = ± 0.25 mm
X.XX = ± 0.10 mm
X.XXX = ± 0.01 mm
ANGLES = $\pm 5^\circ$
UNLESS STATED

MATERIAL:

SEE TABLE

FINISH:

SEE TABLE

S/AREA:

mm²

TITLE: 2.54mm PITCH SIL
SMT VERTICAL PIN HEADER WITH
P/PLACE, TAPE & REEL (L/HAND)

DRAWING NUMBER:

M20-877XXXXR

SHT
3 OF 4

Customer Information Sheet

DRAWING No.: M20-877XXXXR

SHEET 4 OF 4

IF IN DOUBT - ASK

©

NOT TO SCALE

THIRD ANGLE PROJECTION

ALL DIMENSIONS IN mm

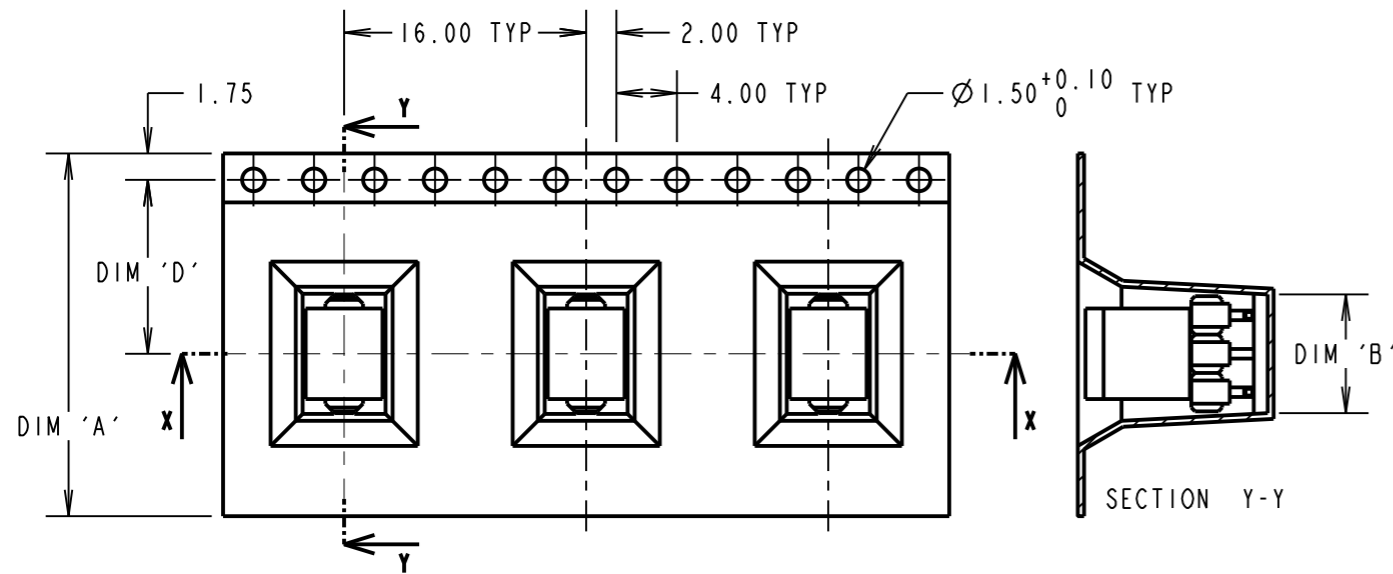

TAPE DETAILS FOR 02 & 03 WAY

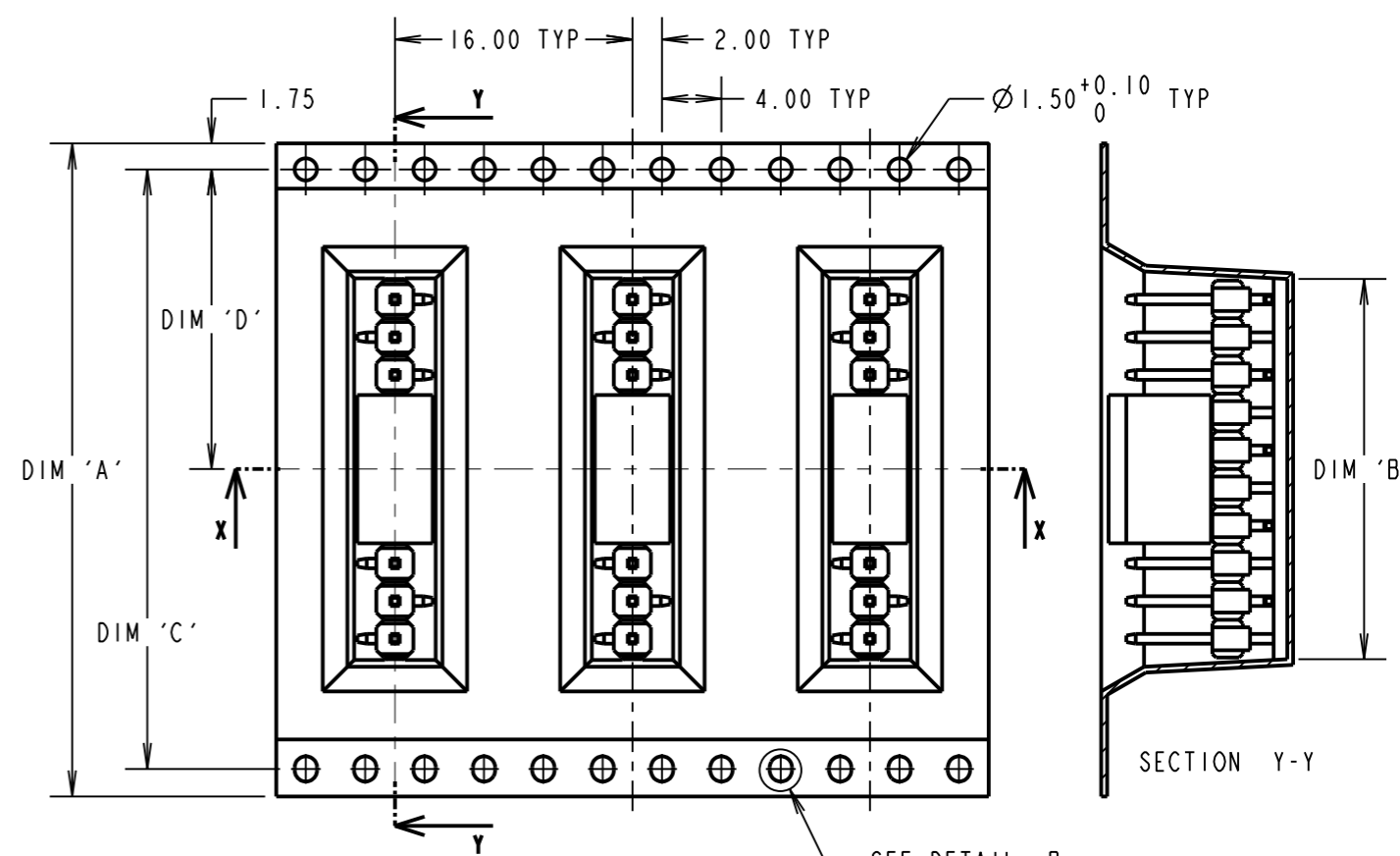
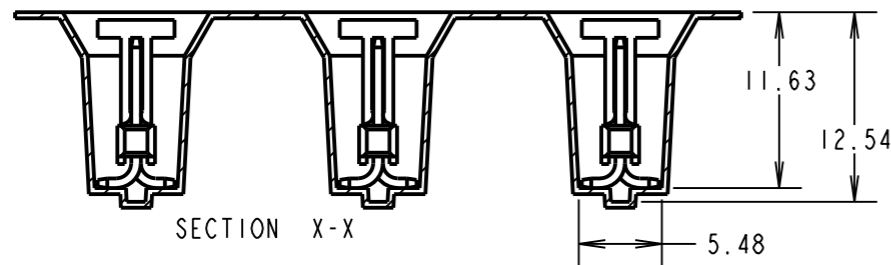

TAPE DETAILS FOR 04,06,08,10,15,19 & 28 WAY

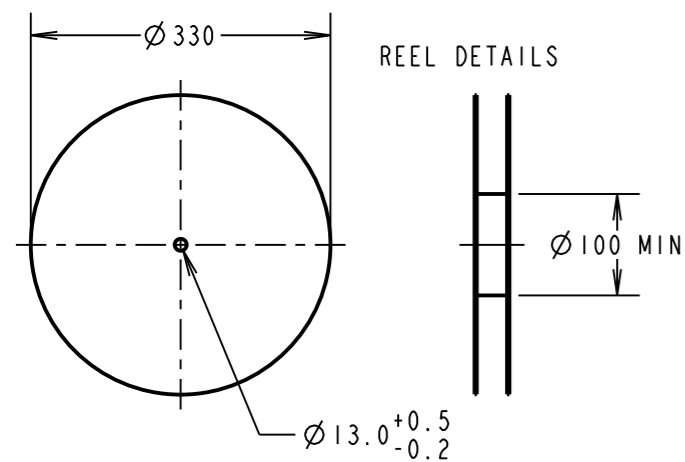
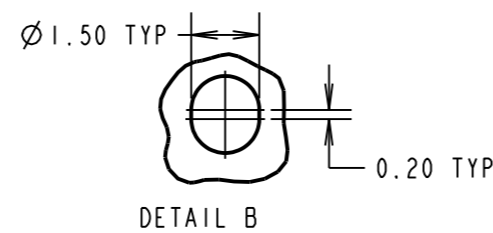
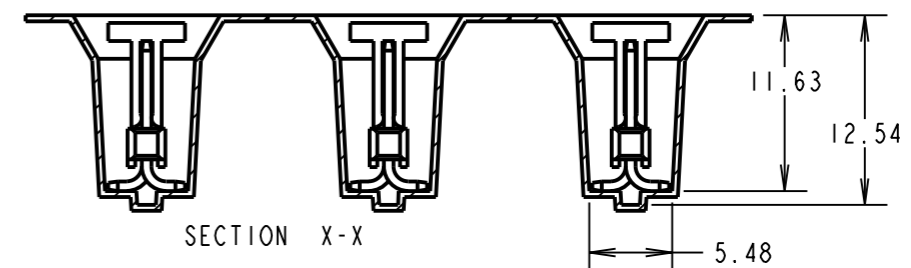

REEL DETAILS

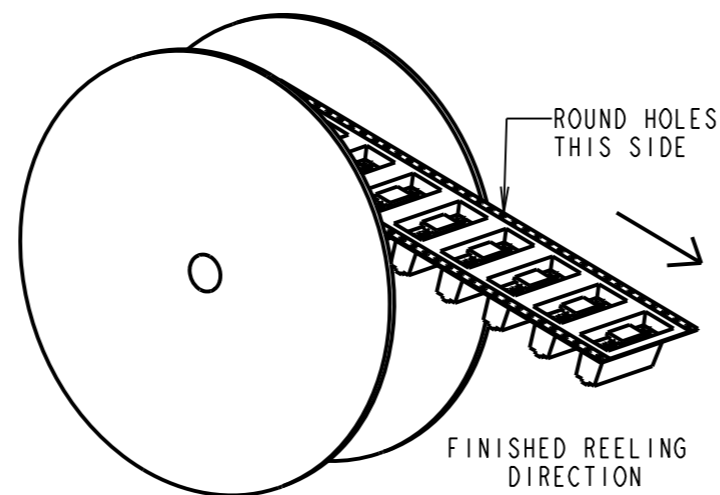

HARWIN PART No.	DIM 'A'	DIM 'B'	DIM 'C'	DIM 'D'
M20-87702XXR	24.00±0.30	5.31	-	11.50
M20-87703XXR		7.85	-	11.50
M20-87704XXR	32.00±0.30	10.39	28.40	14.20
M20-87706XXR		15.47		
M20-87708XXR	44.00±0.30	20.55	40.40	20.20±0.15
M20-87710XXR		25.63		
M20-87715XXR	56.00±0.30	43.57	52.40	26.20±0.15
M20-87719XXR	72.00±0.30	53.73	68.40	34.20±0.30
M20-87728XXR	88.00±0.30	76.59	84.40	42.20±0.30

NOTES:

1. QUANTITY PER REEL = 02 TO 19 WAYS = 450 PIECES, 28 WAYS = 300 PIECES.
2. FOR CONNECTOR DIMENSIONS, SEE SHEET 3.
3. TAPE AND REELING IS IN GENERAL ACCORDANCE WITH ELECTRONIC INDUSTRIES ASSOCIATION EIA-481.

SB	17	05.03.15	12764
NAME	ISS.	DATE	C/NOTE
APPROVED:		S. BENNETT	
CHECKED:		M. PLESTED	
DRAWN:		J. KEIR	
CUSTOMER REF.:			
ASSEMBLY DRG:			

HARWIN

www.harwin.com
technical@harwin.com

THIS DRAWING AND ANY INFORMATION OR DESCRIPTIVE MATTER SET OUT HEREON ARE CONFIDENTIAL AND COPYRIGHT PROPERTY OF THE HARWIN GROUP AND MUST NOT BE DISCLOSED, LOANED, COPIED OR USED FOR MANUFACTURING, TENDERING OR FOR ANY OTHER PURPOSE WITHOUT THEIR WRITTEN PERMISSION.

TOLERANCES
X. = ±1mm
X.X = ±0.50mm
X.XX = ±0.10mm
X.XXX = ±0.01mm
ANGLES = ±5°
UNLESS STATED

MATERIAL:
SEE ABOVE
FINISH: SEE ABOVE
S/AREA: mm²

TITLE: 2.54mm PITCH SIL SMT VERTICAL PIN HEADER WITH P/PLACE, TAPE & REEL (L/HAND)
DRAWING NUMBER:
M20-877XXXXR
SHT 4 OF 4