

HF
Halogen Free

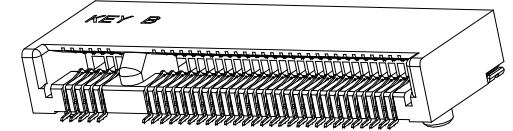
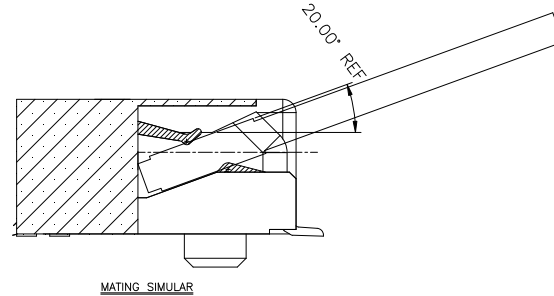
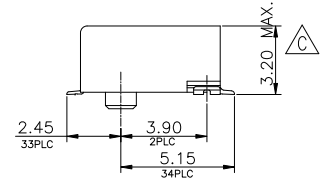
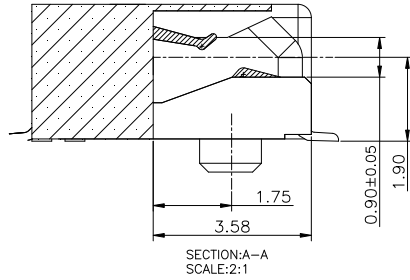
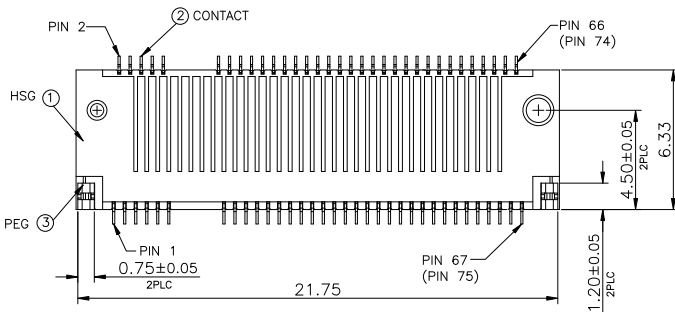
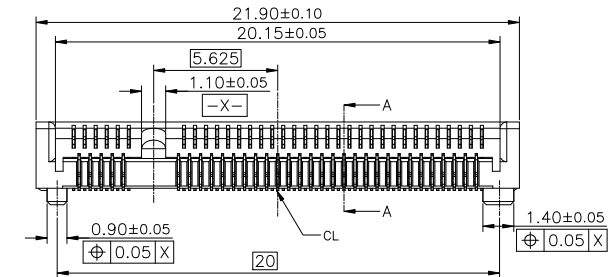
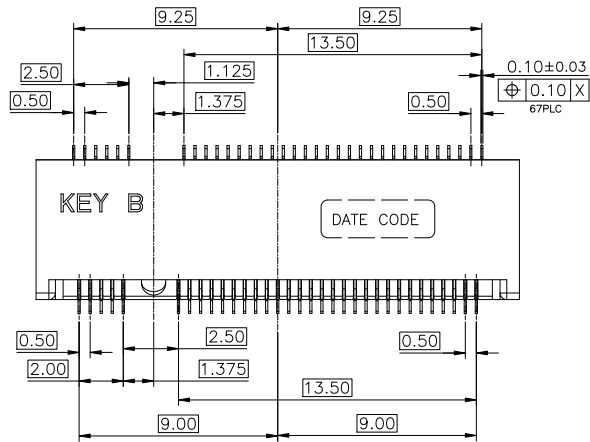

- NOTES:
- MATERIAL:
 - 1.1 HOUSING:HIGH TEMPERATURE THERMOPLASTIC,UL94V-0,COLOR:BLACK.
 - 1.2 CONTACT:COPPER ALLOY.
 - 1.3 SOLDER PEG:STAINLESS STEEL.
 - FINISH:
 - 2.1 CONTACT: UNDERPLATING NICKEL 50u" MIN OVERALL MATING AREA:GOLD PLATING,THICKNESS SEE TABLE SOLDER AREA:GOLD FLASH 1u"MIN.
 - 2.2 SOLDER PEG: UNDERPLATING NICKEL 50u" MIN OVERALL 80u"MIN MATTE TIN ON SURFACE
 - DATE CODE : YYWDLX
 - YY: YEAR (09: 2009)
 - WW: WEEK (25: THE 25TH WEEK)
 - D: DAY (1~7: SUNDAY~SATURDAY)
 - L: LINE NUMBER OF ASSEMBLY (A: LINE A)
 - X: D OR N (D: DAY; N: NIGHT)
 - PRODUCT SPECIFICATION SEE FCI GS-12-1195
 - PART NUMBER DESCRIPTION: 10128787-00XRFL

- LF:LEAD FREE & RoHS COMPLIANCE
- PACKAGE CODE: R: TAPE & REEL PACKING
- PLATING CODE:
 - 1: GOLD FLASH ON CONTACT AREA
 - 4: 15u"Min GOLD ON CONTACT AREA
 - 5: 30u"Min GOLD ON CONTACT AREA

30u" Au	10128787-005RFL
15u" Au	10128787-004RFL
GOLD FLASH	10128787-001RFL
CONTACT AREA	FCI P/N

mat'l. code		surface	tolerance	projection	product family
ltr	ecn no	dr	date	tolerances unless otherwise specified	title
A		BF	2013-04-18	angles	M.2 CONNECTOR 3.2H_STD_KEY B
B	ELX-T-19318	BF	2014-11-10	incl	
C	ELX-T-20858	TAI	2015-05-11	X°±2°	
		dr	BEER FU	2013-05-02	scale
		enr	BEER FU	2013-05-02	FCI
		chr	BEER FU	2013-05-02	
		appd	BEER FU	2013-05-02	
sheet index	revision sheet	C	C	C	3
		dwg no	sheet 1 of 3		size
		10128787		A4	
		type Customer Drawing			

HF
Halogen Free



PLUG PCB

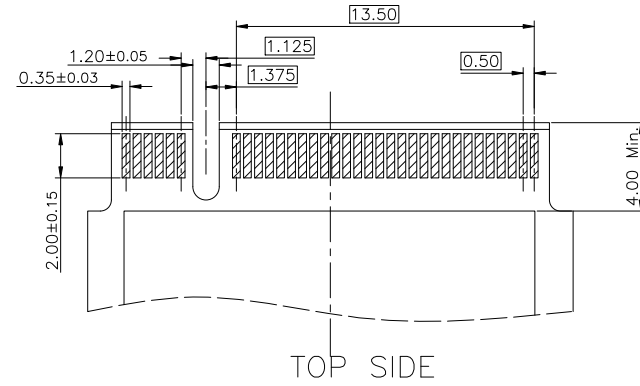
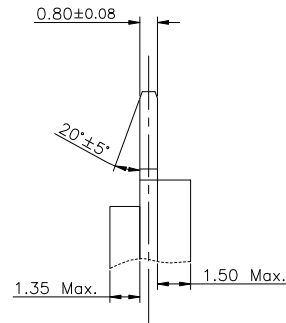
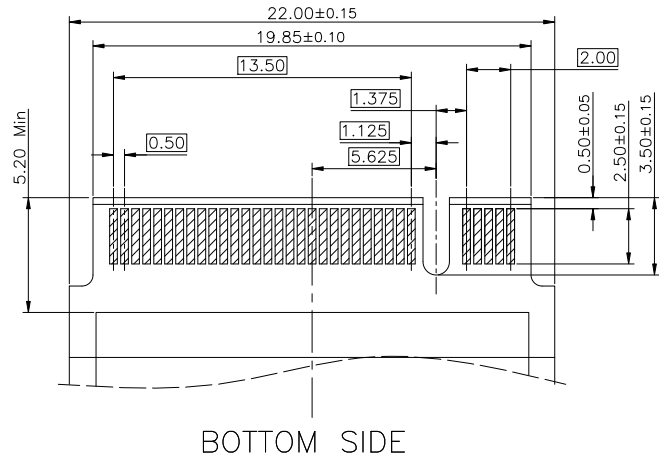

RECOMMENDED M.2(NGFF) MOUNTING TYP PCB_LAYOUT

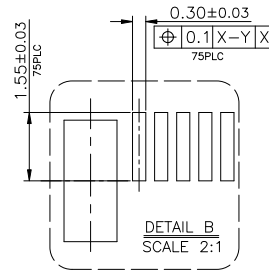
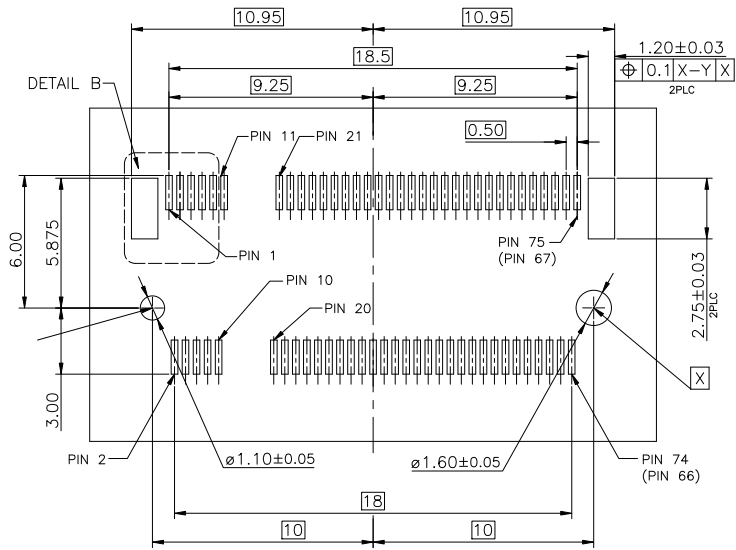

	dwg no	sheet 2 of 3	size
	10128787		A4
	type Customer Drawing		

sheet index	revision sheet	C	C	C											
	1	2	3												

HF
Halogen Free



FEEDING DIRECTION

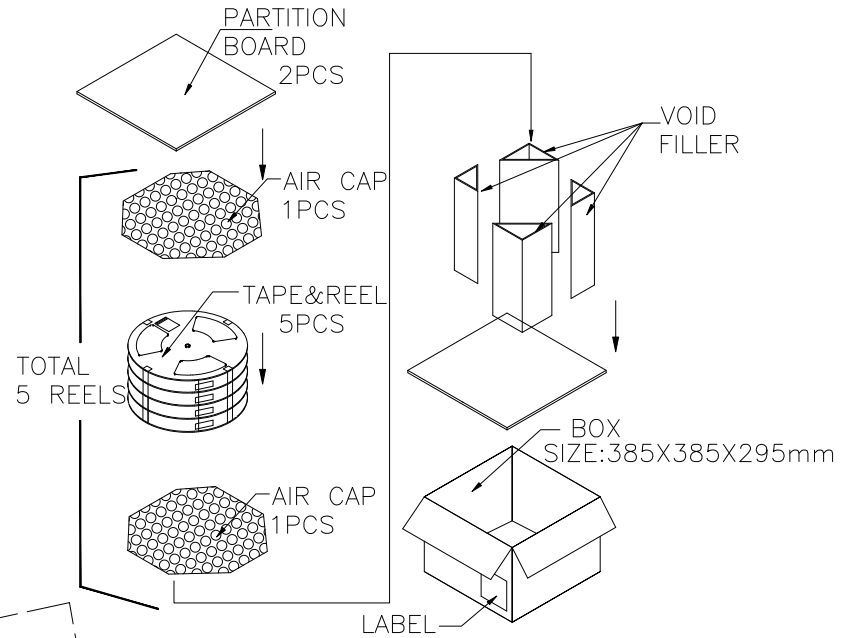
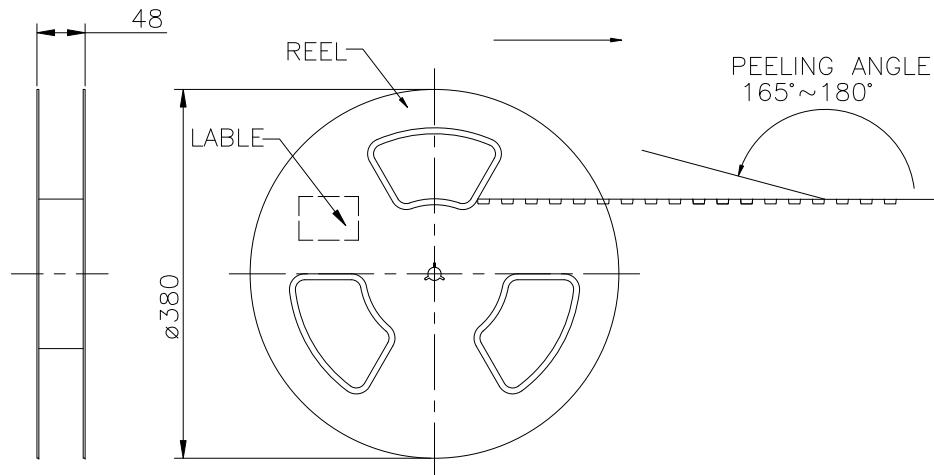

A

A

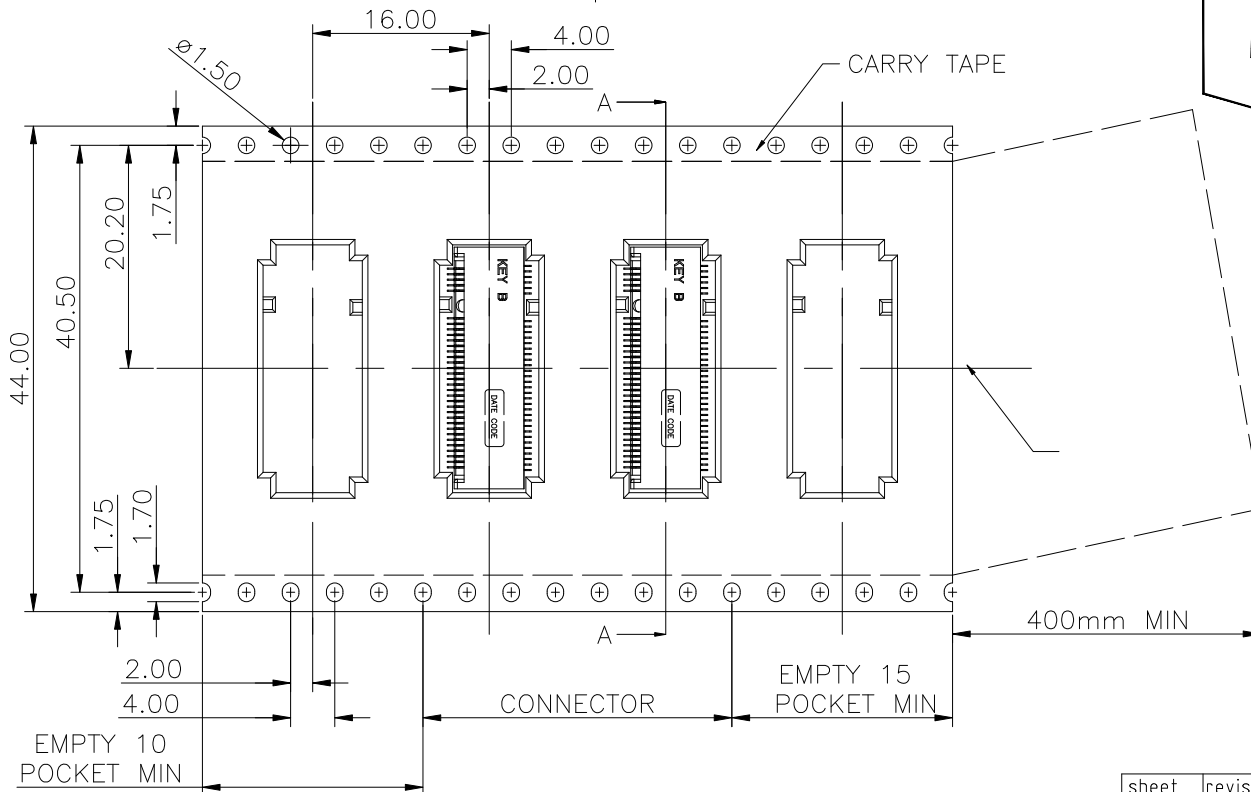

B



1400	5	7000	7.85Kg	3.5Kg
PCS/ TAPE	REELS/ BOX	PCS/BOX	GROSS WEIGHT	NET WEIGHT



dwg no	sheet 3 of 3	size
10128787		A4
type	Customer Drawing	

sheet index	revision sheet	C	C	C																
	1	2	3																	

B