

Apr.1.2017 Copyright 2017 HIROSE ELECTRIC CO., LTD. All Rights Reserved.

COUNT	DESCRIPTION OF REVISIONS	BY	CHKD	DATE	COUNT	DESCRIPTION OF REVISIONS	BY	CHKD	DATE

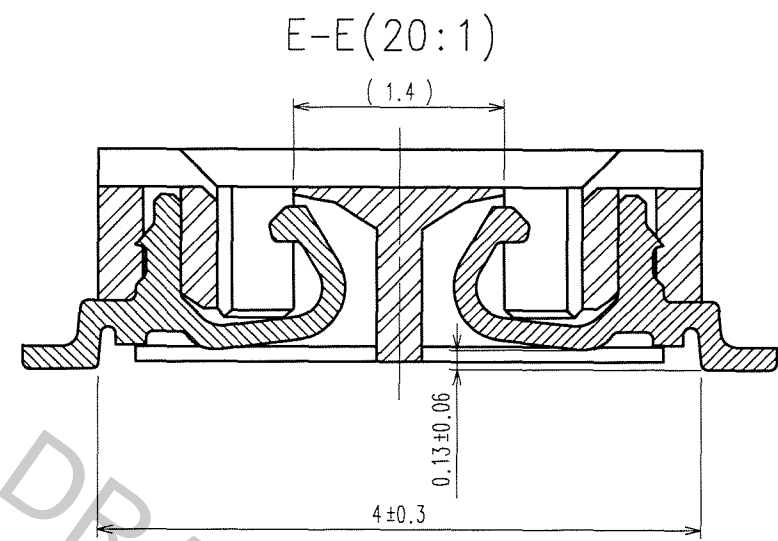

CONTACTS	A	B	C	D
20	6.6	5.62	4.18	3.6
30	8.6	7.62	6.18	5.6
40	10.6	9.62	8.18	7.6
50	12.6	11.62	10.18	9.6
60	14.6	13.62	12.18	11.6
70	16.6	15.62	14.18	13.6
80	18.6	17.62	16.18	15.6
100	22.6	21.62	20.18	19.6
120	26.6	25.62	24.18	23.6

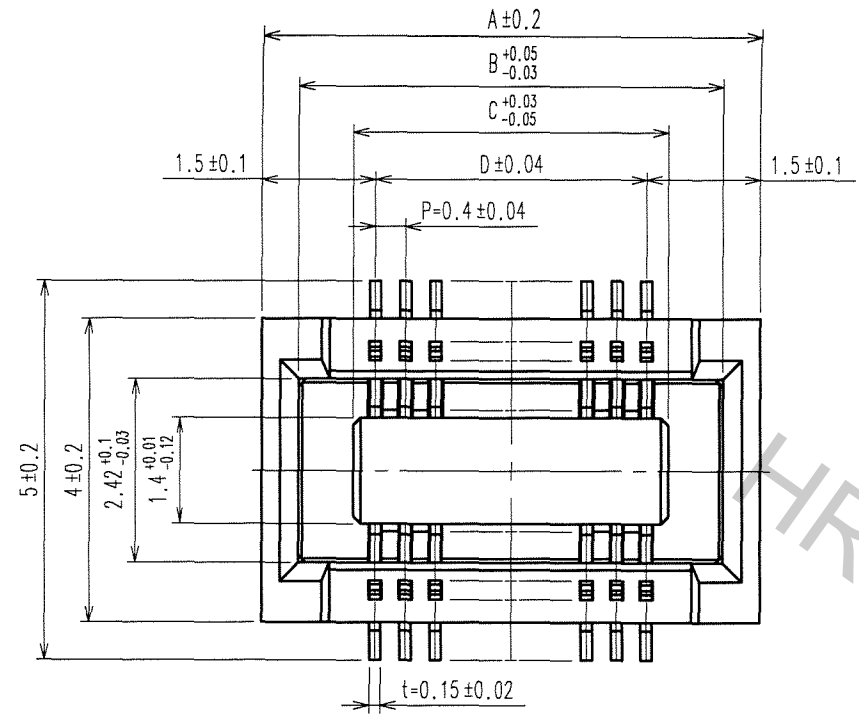
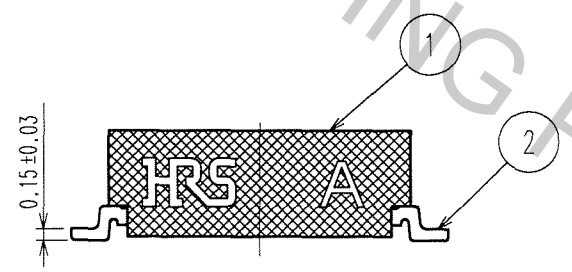
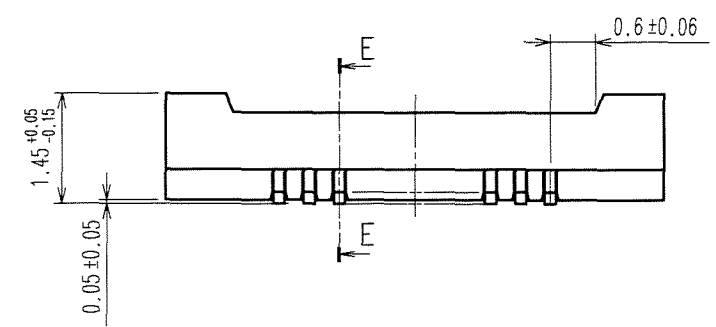

RECOMMENDED PATTERN

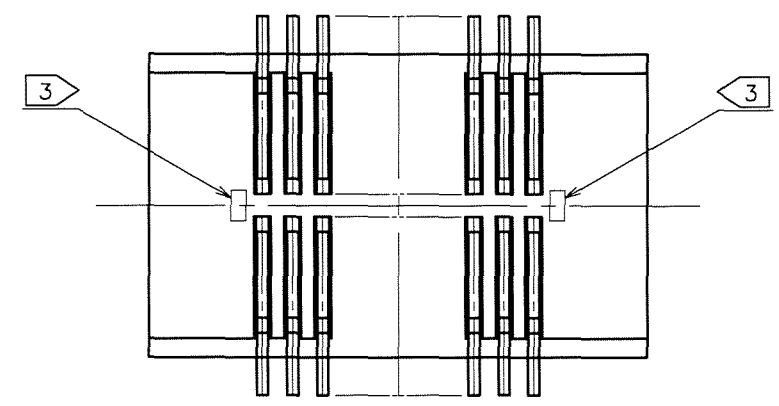
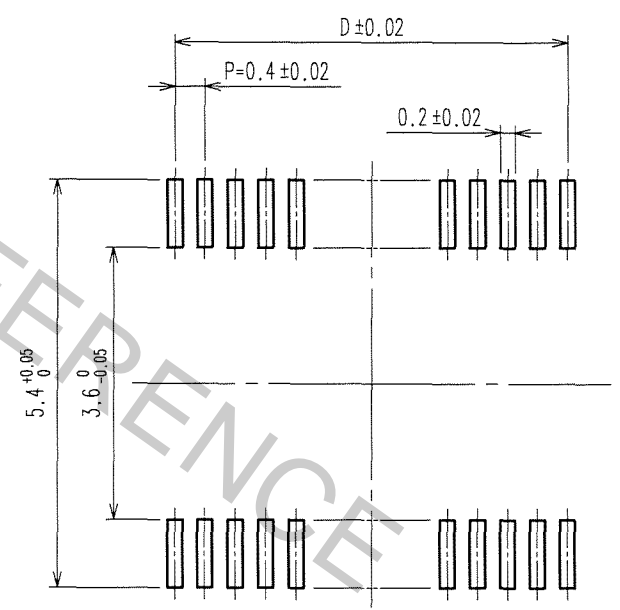

- NOTES
- LEAD CO-PLANARITY SHALL BE 0.1mm MAX.
  - IN CASE OF SOLDERING A CONTACT AREA MANUALLY, CLEANING SHALL BE REQUIRED.
  - PREVENTIVE HOLE FOR SINKAGE MAY BE SETUP AT THE INDICATED POSITION.
  - THIS PRODUCT TO BE SHIPPED BY TAPE AND REEL PACKAGE. REFER TO NEXT SHEET FOR DETAILS OF PACAGING SPECIFICATIONS.
  - USE METAL SCREEN ,THICKNESS 0.12mm. SET UP THE METAL SCREEN HOLE TO THE PATTERN IN 70%.

2	PHOSPHOR BRONZE	CONTACT AREA:GOLD PLATED 0.05μ m min LEAD AREA:GOLD PLATED 0.05μ m min UNDER PLATING:NICKEL PLATED 1μ m min	5	PS	BLACK (PLASTIC REEL)
1	LCP	NATURAL (BLACK),UL94V-0	4	POLYESTER	CLEAR (COVER TAPE)
			3	PS	CLEAR (EMBOSSD CARRIER TAPE)
NO.	MATERIAL	FINISH, REMARKS	NO.	MATERIAL	FINISH, REMARKS

CODE NO. (OLD)	DRAWN	DESIGNED	CHECKED	APPROVED	RELEASED
	<i>J. Michida</i>	<i>J. Michida</i>	<i>T. Miyajaki</i>	<i>K. Ikeda</i>	
	07.9.29	07.9.29	07.09.29	07.09.29	
SCALE	DRAWING NO.	PART NO.			
10 : 1	EDC3-314220-01	DF18C-*DS-0.4V(81)			
UNITS	HRS	HIROSE ELECTRIC CO., LTD	CODE NO.	CL684	1/2
mm					

TO

Apr.1.2017 Copyright 2017 HIROSE ELECTRIC CO., LTD. All Rights Reserved.

COUNT	DESCRIPTION OF REVISIONS	BY	CHKD	DATE	COUNT	DESCRIPTION OF REVISIONS	BY	CHKD	DATE

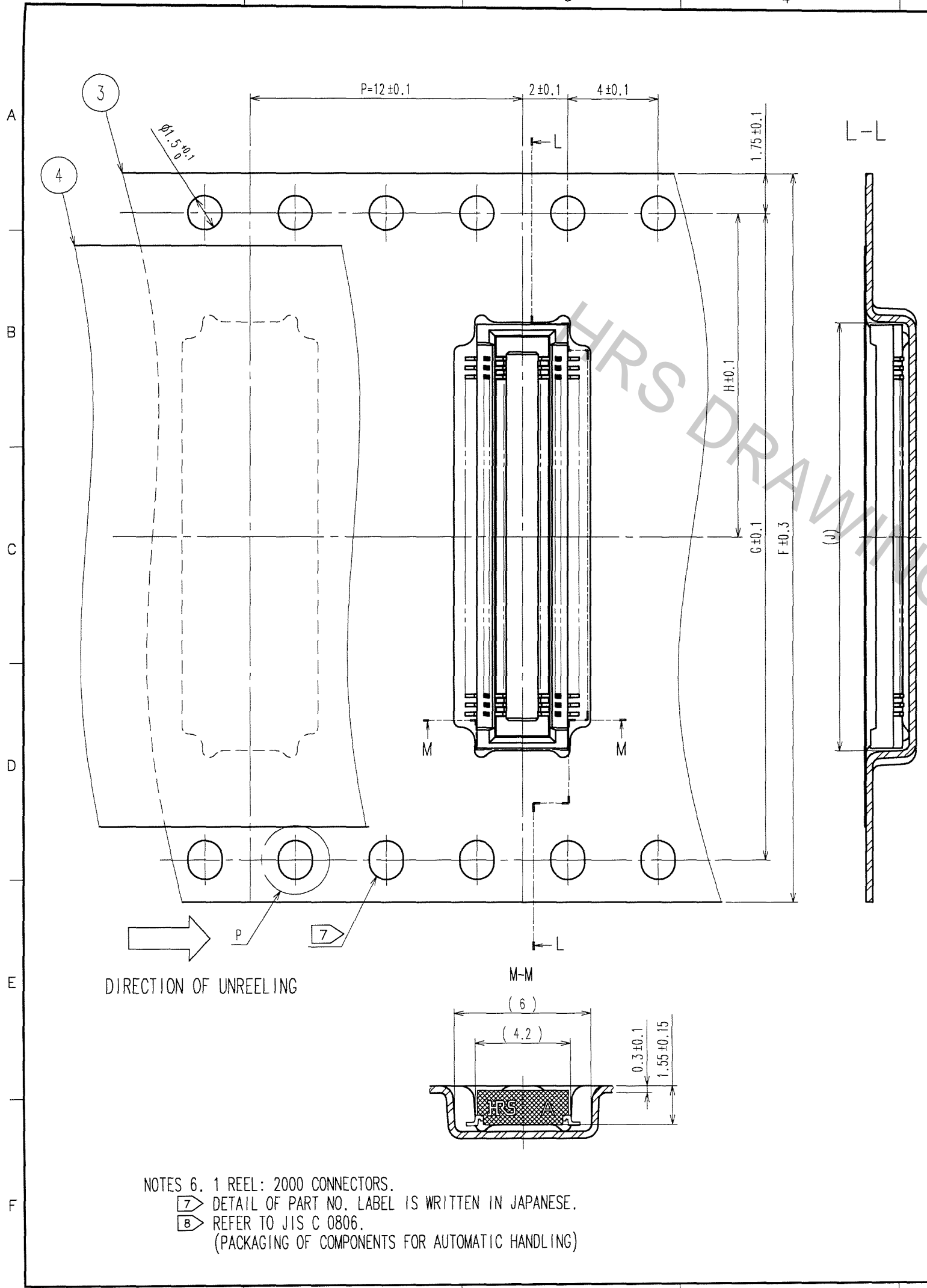

STYLE AND DIMENSION OF REEL (FREE)

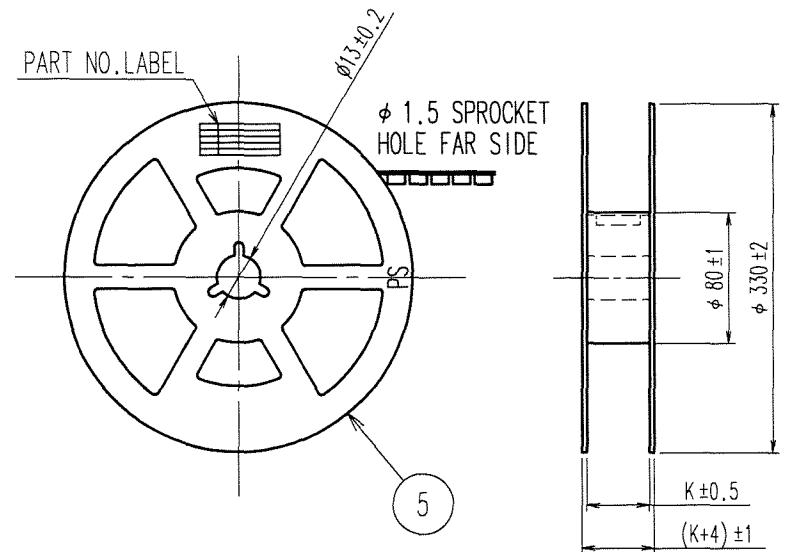

CONTACTS	F	G	H	J	K
20	16	-	7.5	6.8	17.5
30	16	-	7.5	8.8	17.5
40	24	-	11.5	10.8	25.5
50	24	-	11.5	12.8	25.5
60	24	-	11.5	14.8	25.5
70	24	-	11.5	16.8	25.5
80	32	28.4	14.2	18.8	33.5
100	44	40.4	20.2	22.8	45.5
120	44	40.4	20.2	26.8	45.5

7> DETAIL OF PART No. LABEL

DATE OF MANUFACTURED	** ** *
CL No.	684-*****-81
PART No.	DF18C-*DS-0.4V(81)
QUANTITY	2000 KO
SUPPLIER	HIROSE ELECTRIC CO.,LTD.

8> TAPING

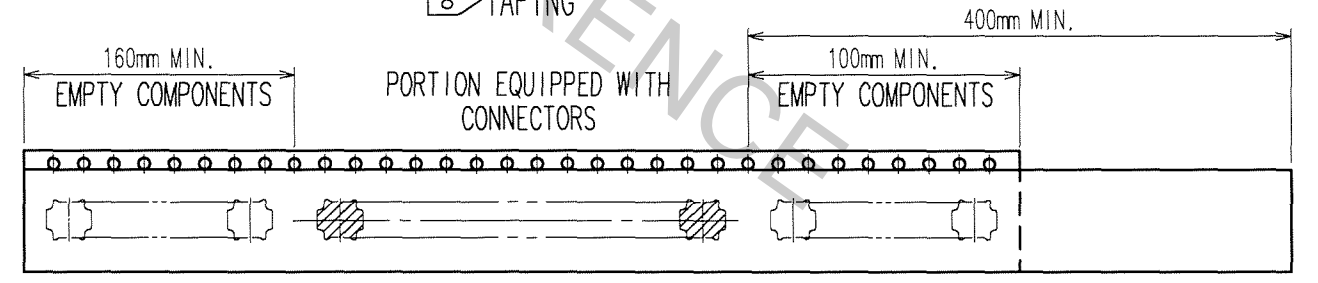

NOTES 6. 1 REEL: 2000 CONNECTORS.  
 7> DETAIL OF PART No. LABEL IS WRITTEN IN JAPANESE.  
 8> REFER TO JIS C 0806.  
 (PACKAGING OF COMPONENTS FOR AUTOMATIC HANDLING)

CODE NO. (OLD)	DRAWN	DESIGNED	CHECKED	APPROVED	RELEASED
	J. Michida	J. Michida	T. Miyazaki	K. Ikeda	
	07.9.29	07.9.29	07.09.29	07.09.29	
DRAWING NO. EDC3-314220-01	PART NO. DF18C-*DS-0.4V(81)		CODE NO. CL684		
SCALE FREE	HIROSE ELECTRIC CO., LTD		2/2		

TO

1	2	3	4						
COUNT	DESCRIPTION OF REVISIONS	BY	CHKD	DATE	COUNT	DESCRIPTION OF REVISIONS	BY	CHKD	DATE
△				..	△				..
△					△				..
△					△				..

A

■ NOTES WHEN MATING

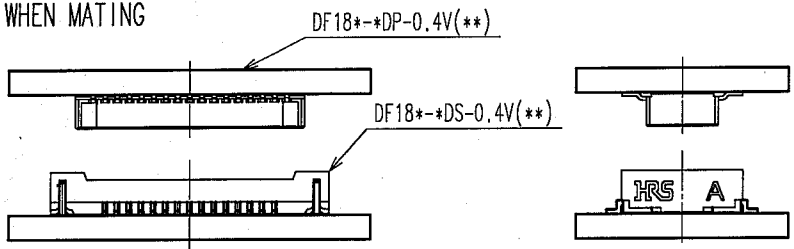

FIGURE-1

PLEASE LOCATE EACH CONNECTOR IN PARALLEL WHEN YOU PUT THEM IN MATING POSITION.

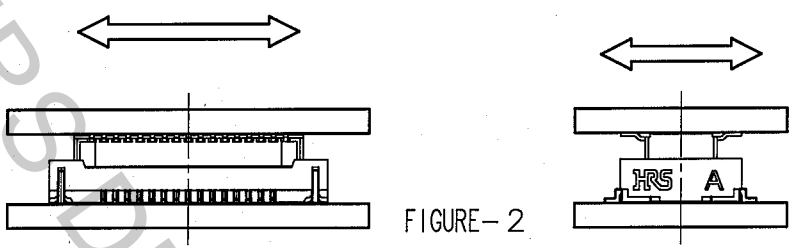

FIGURE-2

THE INSULATOR WILL BE DAMAGED AND THE CONTACTS WILL BE DEFORMED IF THE CONNECTORS ARE LOCATED INCLINED AND MATED BY EXCESSIVE FORCE.

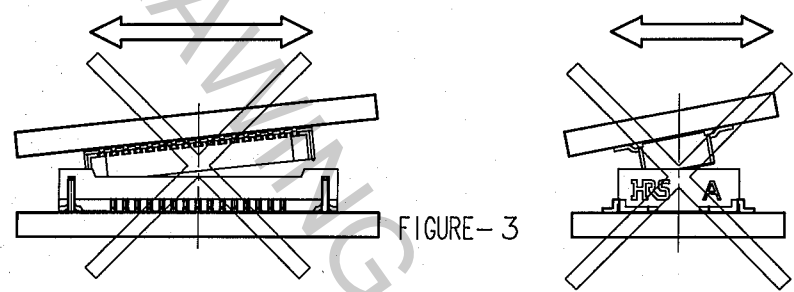

FIGURE-3

WHEN YOU LOCATE TWO CONNECTORS IN A PROPER POSITION, THEY WILL GO DOWN SLIGHTLY AT A LOWER LEVEL AND YOU WILL FIND THAT THEY GET LOCATED CORRECTLY. PLEASE MATE EACH CONNECTOR IN PARALLEL AFTER YOU CONFIRMED THAT THEY GO DOWN LOWER TO SOME EXTENT.

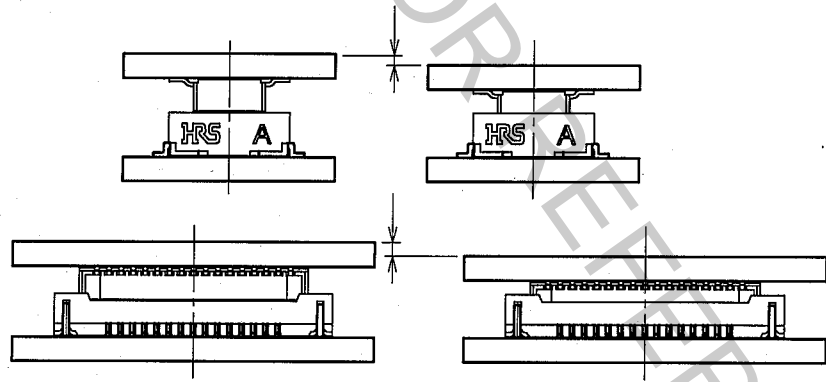

FIGURE-4

THE MATED CONDITIONS CAN BE RELEASED BY A DROP IMPACT OR THE APPLIED FORCE CAUSED BY FPC-HANDLING. FIX THE CONNECTORS BY APPLYING PRESSURE IN THE MATING DIRECTION WITH THE DEVICE OR A BUFFER MATERIAL.

CODE NO. (OLD)		DRAWN	DESIGNED	CHECKED	APPROVED	RELEASED
NOTES WHEN MATING		<i>J. Michioka</i> 06.11.15	<i>J. Michioka</i> 06.11.15	<i>K. Akada</i> 06.11.15	<i>M. Kobayashi</i> 06.11.15	
 SCALE FREE : 1 UNITS mm	DRAWING NO. EDC4-312210-18	PART NO. DF18 SERIES				
	HIROSE ELECTRIC CO., LTD.				CODE NO. CL684	1/2

TO



1	2	3	4						
COUNT	DESCRIPTION OF REVISIONS	BY	CHKD	DATE	COUNT	DESCRIPTION OF REVISIONS	BY	CHKD	DATE
△				..	△				..
△					△				..
△					△				..

■ Notes when extracting

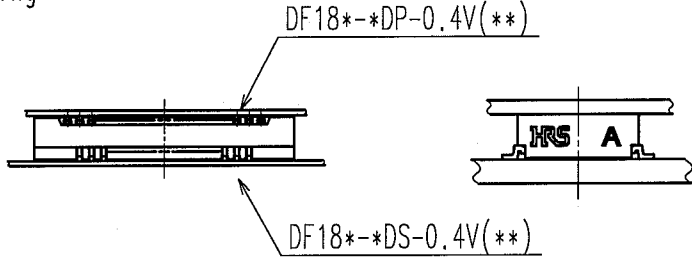

Figure-1

When you extract connectors, please extract in parallel.

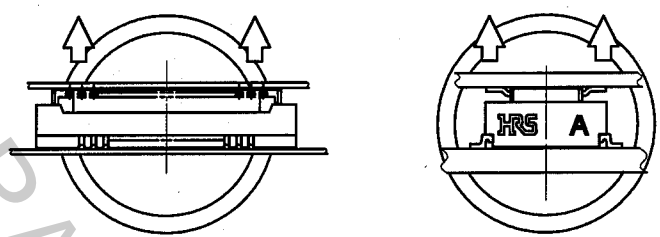

Figure-2

If you're unable to extract in parallel due to set structure or space, please extract as Figure-3 (in longer dimension)  
Please be careful not to damage contacts at sides, where stress is likely to gather when connectors are mounted on soft FPC.

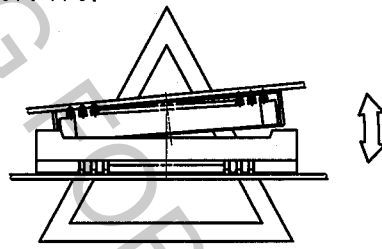

Figure-3

Please do not extract as Figure-4.  
The stress concentrates on one row, and might damage connectors to malfunction.

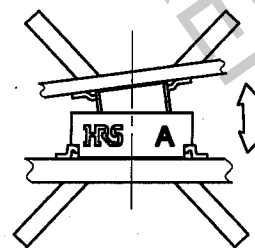
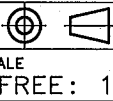



Figure-4

TO

NOTES WHEN EXTRACTING		DRAWN <i>J. Michioka</i> 06.11.15	DESIGNED <i>J. Michioka</i> 06.11.15	CHECKED <i>H. Akeda</i> 06.11.15	APPROVED <i>M. Nakamura</i> 06.11.15	RELEASED
 SCALE FREE: 1 UNITS mm	DRAWING NO. EDC4-312210-18	PART NO. DF18 SERIES				2/2
 HIROSE ELECTRIC CO., LTD.		CODE NO. CL684		FORM NO. 228		



1			2			3			4		
COUNT	DESCRIPTION OF REVISIONS	BY	CHKD	DATE	COUNT	DESCRIPTION OF REVISIONS	BY	CHKD	DATE		
△					△						
△					△						
△					△						

## RECOMMENDED REFLOW PROFILE FOR LEAD FREE SOLDERING

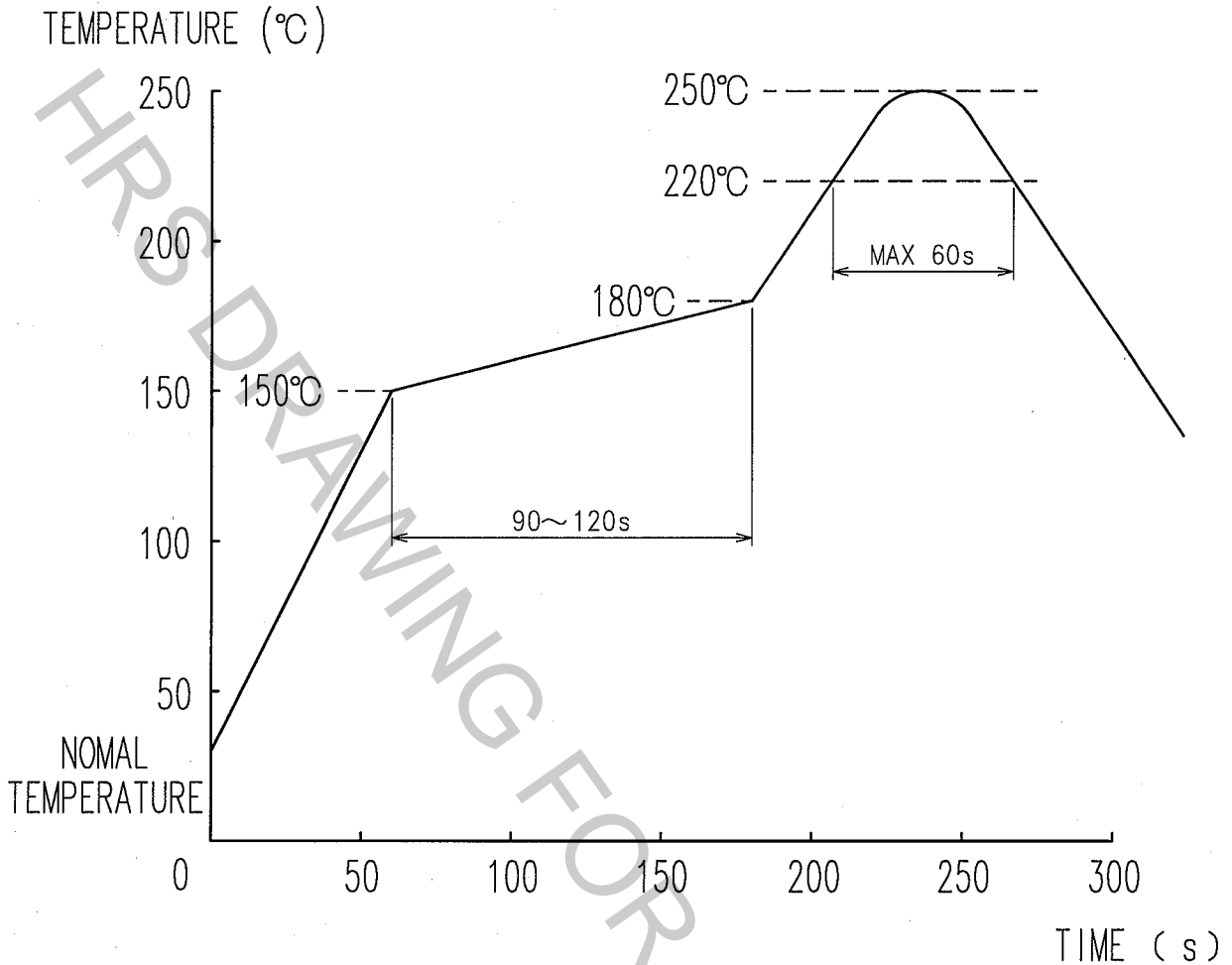

- NOTE
1. MAX 250°C
  2. SOLDERING AREA : 220°C OR MORE      MAX 60 s
  3. PREHEATING AREA : 150~180°C      90~120 s
  4. MAXIMUM TWICE ACTION IS ALLOWED UNDER THE SAME CONDITION.

CODE NO. (OLD)		DRAWN	DESIGNED	CHECKED	APPROVED	RELEASED
		<i>J. Michida</i>	<i>J. Michida</i>	<i>T. Miyazaki</i>	<i>K. Ikeda</i>	
		06.10.12	06.10.12	06.10.13	06.10.13	
DRAWING NO.		PART NO.				
EDC4-163817-18		DF18 SERIES				
UNITS		CODE NO.				
mm		CL684				

TO