

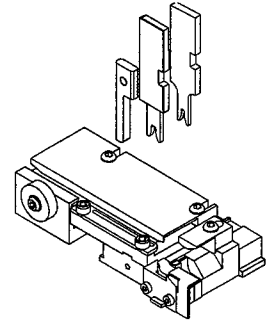

**SPECIFICATION SHEET**  
**T2 Terminator**  
**63853-5000**  
**REVISION A**



**SCOPE**

Terminal Series No		Wire Size Awg	Wire Size (mm <sup>2</sup> )	Insulation Diameter mm	Insulation Diameter (in)	Strip Length mm	Strip Length (in)
50397-8*	50398-8*	22-28	(.034-.079)	1.8-1.15	(.071-.045)	2.6-3.1	(.102-.122)

**DEFINITION OF TERMS**

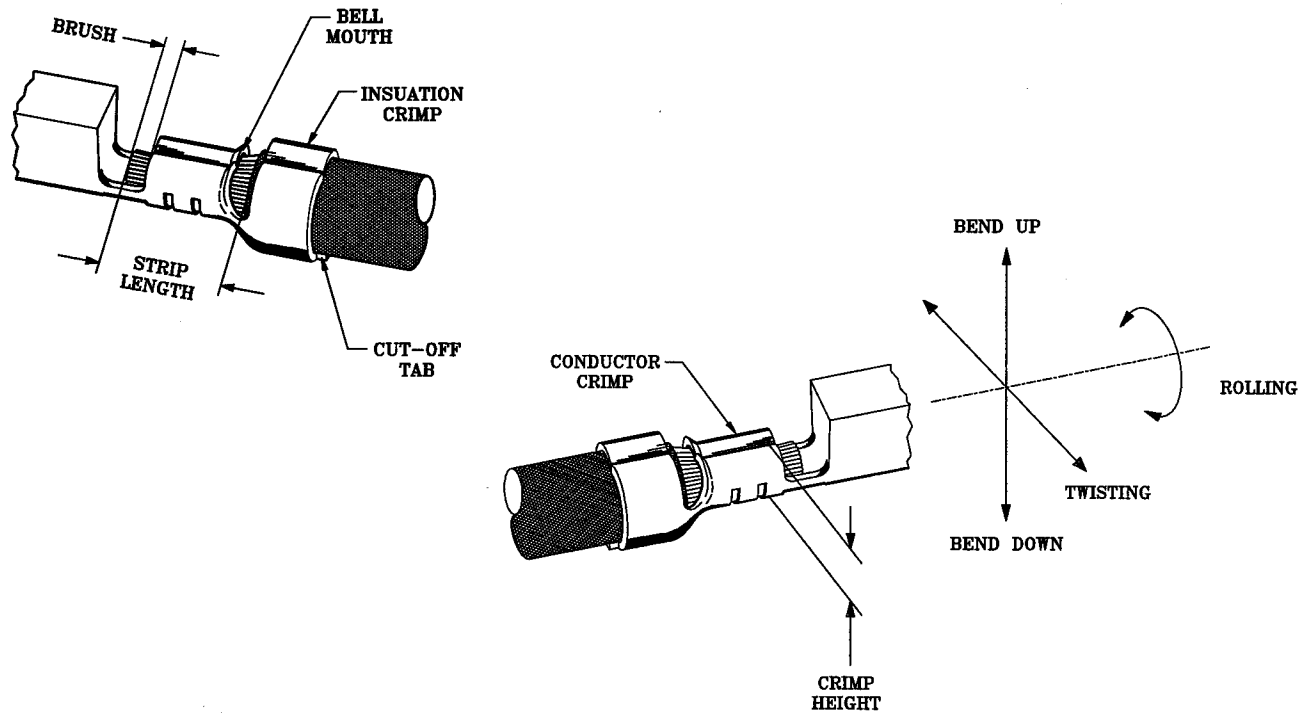

The above terminal drawing is a generic terminal representation. It is not an image of a terminal listed in the scope

## SPECIFICATIONS

Terminal Series No.		Bellmouth mm (in)		Cut-Off Tab Max. mm (in)		Conductor Brush mm (in)	
50397-8*	50398-8*	0.05-0.60	(.002-.023)	0.2	(.008)	0-0.8	(.000-.031)

Terminal Series No.		Bend Up Degree	Bend Down Degree	Twist Degree	Roll	Punch Width mm Conductor Insulation	
50397-8*	50398-8*	3	3	3	6	1.20	1.80

The above specifications are guidelines to an optimum crimp.

## CONDITIONS

After crimping, the conductor profile should measure the following.

Terminal Series		Wire Size Awg (mm <sup>2</sup> )		Crimp Height mm (in)		Pull Force Min N (lbs)	
50397-8*	50398-8*	22	(0.35)	0.84-0.89	.033-.035	39.2	(8.80)
50397-8*	50398-8*	24	(0.20)	0.76-0.81	.030-.032	29.4	(6.60)
50397-8*	50398-8*	26	(0.12)	0.71-0.76	.028-.030	19.6	(4.40)
50397-8*	50398-8*	28	(0.08)	0.67-0.72	.026-.028	9.8	(2.20)

Pull Force measured with no influence from the insulation crimp

## PARTS LIST

Item Number	Order Number	Eng Number	Description	Qty	Kit Part
1	63444-1212	634441212	Conductor Punch	1	Y
2	63445-1221	634451221	Conductor Anvil	1	Y
3	63446-1815	634461815	Insulation Punch	1	Y
4	63445-1824	634451824	Insulation Anvil	1	Y
5	63443-0002	634430002	Cut-Off Plunger	1	Y
6	63443-0012	634430012	Front Plunger Retainer	1	Y
7	011-24-1067	4996-4	Cut-Off Plunger Spring	1	
8	011-40-4039	8302-5	Front Plunger Striker	1	
9	63443-0021	634430021	Lower Tooling Key	1	
10	63443-6003	634436003	Rear Cover	1	
11	011-18-4083	60707-8	Front Cover	1	
12	63443-2406	634432406	Anvil Mount	1	
13	63443-4005	634434005	Wire Stop	1	
14	63443-0009	634430009	Scrap Chute	1	
15	63800-8500	638008500	T2 Terminator	1	
70	63853-5070	638535070	Tool Kit (All "Y" Items)	0	

## NOTES

1. We recommend an extra perishable tooling kit be maintained at your facility.
2. Verify tooling alignment by manually cycling the press and Terminator before crimping under power.
3. Slugs , Terminals, Dirt and Oil should be kept clear of work area.
4. This Terminator should only be used in a Molex TM42, TM40, or 3BF Press with a BaseUnit adaptor.
5. **\*\* CAUTION\*\*** To prevent injury never operate this Terminator without the guarding supplied with the TM42 , TM40, or 3BF Press / Base Unit.
6. Wear safety glasses at all times.

# ASSEMBLY DRAWING

The drawing below is a generic drawing representation. Some detail may not be shown. The T2 Terminator assembly and parts list can be found in the T2 Terminator manual.

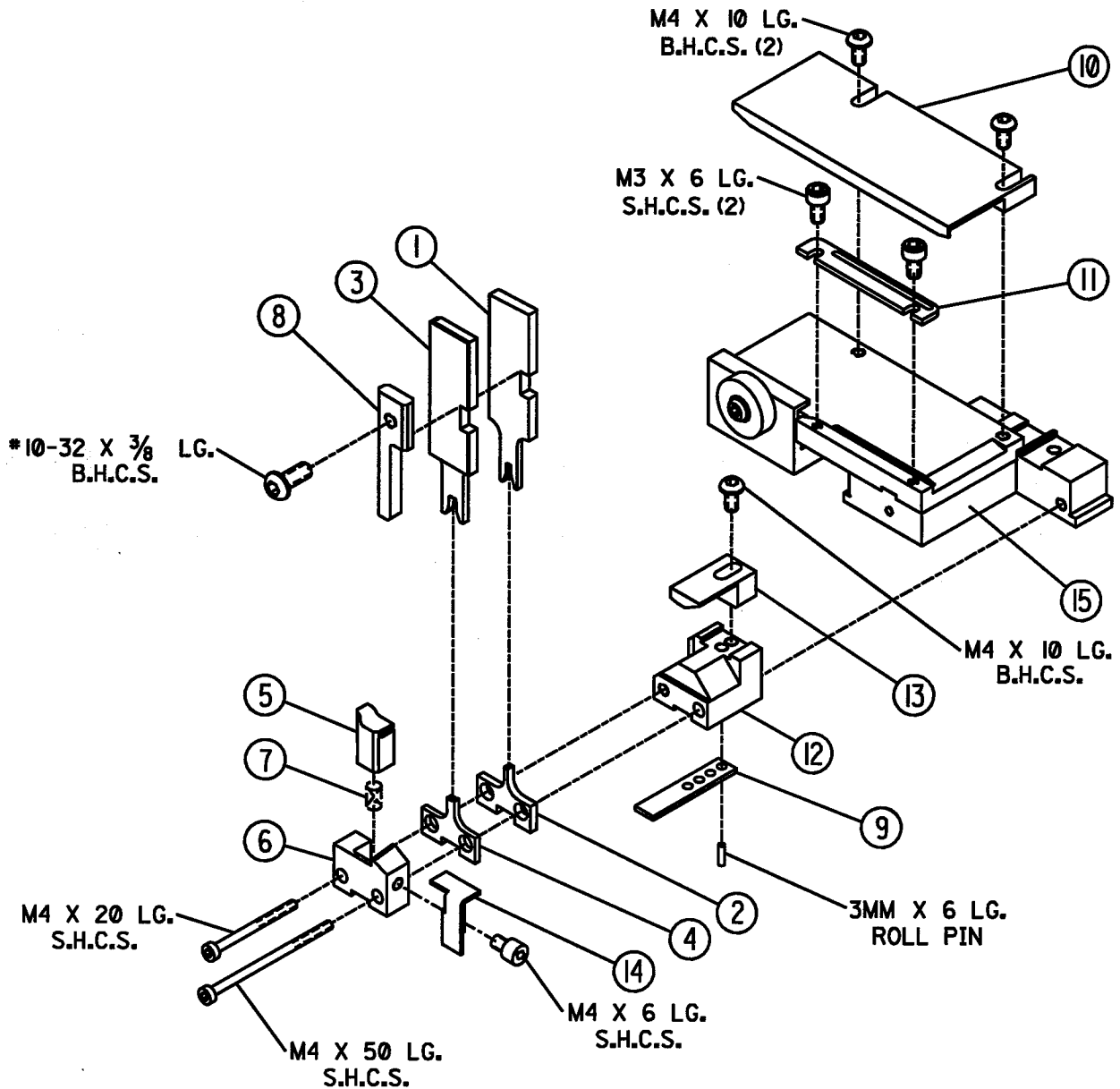

## Note

Depending on the press vintage a feed finger assembly is supplied with the T2 Terminator.

1. To remove the existing feed finger assembly loosen the M4 x 10 mm set screw in the feed lever.
2. Select T2 Feed finger assembly from Terminator box
3. Insert a screwdriver into to slot behind the feed lever and force the 12 mm spring to the right.
4. Slide the T2 feed finger shaft for TM42 (11-40-5307) or (11-40-0123) for TM40 /Base Unit into the feed lever and to the left of the 12 mm spring.
5. Release the 12 mm spring.
6. Position feed finger for selected product. (Ref fig 5.1 T2 Manual)

### TM42 Press

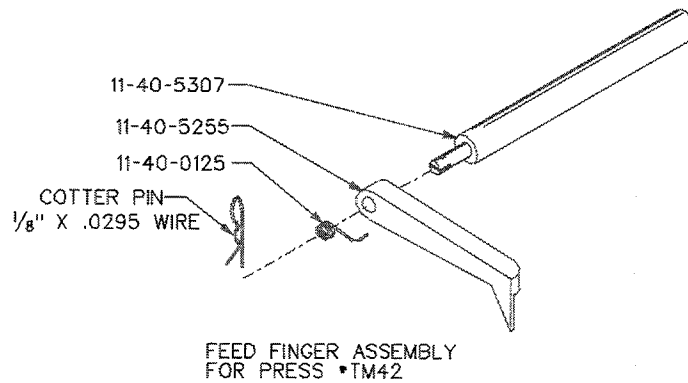

### TM40 Press & BaseUnit & Adaptor

