



Three Port 10/100 Managed Ethernet Switch with MII/RMII for Automotive Applications

PRODUCT FEATURES

Data Brief

Highlights

- SMSC TrueAuto™ automotive quality process
- Up to 200 Mbps via Turbo MII
- High performance, full featured 3-port switch with VLAN, QoS packet prioritization, rate limiting, IGMP monitoring and management functions
- Serial management via I²C™ or SMI
- Unique Virtual PHY feature simplifies software development by mimicking the multiple switch ports as a single port PHY

Target Applications

- Diagnostic interface (for dealership service bay)
- Fast software download (e.g., OBD connector)
- Gateway service interface (dealership, aftermarket repair shop)
- In-Vehicle engineering development interface
- Vehicle manufacturing test interface (production plant assembly line)
- Legislated inspections (emissions check, safety inspections)

Key Benefits

- Ethernet Switch Fabric
 - 32k buffer RAM
 - 512 entry forwarding table
 - Port based IEEE 802.1Q VLAN support (16 groups)
 - IEEE 802.1D spanning tree protocol support
 - Four separate transmit queues available per port
 - Fixed or weighted egress priority servicing
 - QoS/CoS packet prioritization
 - Input priority determined by VLAN tag, DA lookup, TOS, DIFFSERV or port default value
 - Programmable traffic class map based on input priority on per port basis
 - Remapping of 802.1Q priority field on per port basis
 - Programmable rate limiting at the ingress with coloring and random early discard, per port / priority
 - Programmable rate limiting at the egress with leaky bucket algorithm, per port / priority

- IGMP v1/v2/v3 monitoring for multicast packet filtering
- IPV6 multicast listener discovery monitoring
- Programmable broadcast storm protection with global % control and enable per port
- Programmable buffer usage limits
- Dynamic queues on internal memory
- Programmable filter by MAC address
- Switch Management
 - Port mirroring/monitoring/sniffing: ingress and/or egress traffic on any port or port pair
 - Fully compliant statistics (MIB) gathering counters
 - Control registers configurable on-the-fly
- Ports
 - Port 0 - MII MAC, MII PHY, RMII™ PHY modes
 - 2 internal 10/100 PHYs with HP Auto-MDIX support
 - 200 Mbps Turbo MII (PHY or MAC mode)
 - Fully compliant with IEEE 802.3 standards
 - 10BASE-T and 100BASE-TX support
 - Full and half duplex support
 - Full duplex flow control
 - Backpressure (forced collision) half duplex flow control
 - Automatic flow control based on programmable levels
 - Automatic 32-bit CRC generation and checking
 - 2k Jumbo packet support
 - Programmable interframe gap, flow control pause value
 - Full transmit/receive statistics
 - Full LED support per port
 - Auto-Negotiation
 - Automatic polarity correction
 - Automatic MDI/MDI-X
- Serial Management
 - I²C (slave) access to all internal registers
 - MIIM (MDIO) access to PHY related registers
 - SMI (extended MIIM) access to all internal registers
- Other Features
 - General Purpose Timer
 - I²C Serial EEPROM interface
 - Programmable GPIOs/LEDs
- Single 3.3 V power supply
- Packaging
 - 56-pin QFN Lead-Free RoHS compliant package
- Environmental
 - Automotive grade temp. support (-40 to +85 °C)



ORDER NUMBER(S):
LAN89303AM (Tray) FOR 56-PIN, QFN, ROHS-COMPLIANT PACKAGE
LAN89303AMR (Tape & Reel) FOR 56-PIN, QFN, ROHS-COMPLIANT PACKAGE

TrueAuto™

TrueAuto is SMSC's automotive quality process. It has proven its capability to deliver leading edge quality and services to fulfill the needs of even the most demanding automotive customers. It is SMSC's proven total approach to true automotive-grade quality. SMSC's TrueAuto robustness begins with the design for reliability techniques within the silicon IC itself. Automotive-grade excellence and testability are designed into the IC. The IC is fully characterized over many operating parameters to prove the quality of the design under various conditions. It meets or exceeds automotive reliability standards (like AEC-Q100) and customer specific requirements.

In addition, extensive technologies and processes, such as enhanced monitors are used in fabrication of TrueAuto products in order to continuously drive improvements in accordance with SMSC's zero Defects per Million (DPM) goals.



80 ARKAY DRIVE, HAUPPAUGE, NY 11788 (631) 435-6000 or 1(800) 443-SEMI

Copyright © 2011 SMSC or its subsidiaries. All rights reserved.

Circuit diagrams and other information relating to SMSC products are included as a means of illustrating typical applications. Consequently, complete information sufficient for construction purposes is not necessarily given. Although the information has been checked and is believed to be accurate, no responsibility is assumed for inaccuracies. SMSC reserves the right to make changes to specifications and product descriptions at any time without notice. Contact your local SMSC sales office to obtain the latest specifications before placing your product order. The provision of this information does not convey to the purchaser of the described semiconductor devices any licenses under any patent rights or other intellectual property rights of SMSC or others. All sales are expressly conditional on your agreement to the terms and conditions of the most recently dated version of SMSC's standard Terms of Sale Agreement dated before the date of your order (the "Terms of Sale Agreement"). The product may contain design defects or errors known as anomalies which may cause the product's functions to deviate from published specifications. Anomaly sheets are available upon request. SMSC products are not designed, intended, authorized or warranted for use in any life support or other application where product failure could cause or contribute to personal injury or severe property damage. Any and all such uses without prior written approval of an Officer of SMSC and further testing and/or modification will be fully at the risk of the customer. Copies of this document or other SMSC literature, as well as the Terms of Sale Agreement, may be obtained by visiting SMSC's website at <http://www.smisc.com>. SMSC is a registered trademark of Standard Microsystems Corporation ("SMSC"). Product names and company names are the trademarks of their respective holders.

SMSC DISCLAIMS AND EXCLUDES ANY AND ALL WARRANTIES, INCLUDING WITHOUT LIMITATION ANY AND ALL IMPLIED WARRANTIES OF MERCHANTABILITY, FITNESS FOR A PARTICULAR PURPOSE, TITLE, AND AGAINST INFRINGEMENT AND THE LIKE, AND ANY AND ALL WARRANTIES ARISING FROM ANY COURSE OF DEALING OR USAGE OF TRADE. IN NO EVENT SHALL SMSC BE LIABLE FOR ANY DIRECT, INCIDENTAL, INDIRECT, SPECIAL, PUNITIVE, OR CONSEQUENTIAL DAMAGES; OR FOR LOST DATA, PROFITS, SAVINGS OR REVENUES OF ANY KIND; REGARDLESS OF THE FORM OF ACTION, WHETHER BASED ON CONTRACT; TORT; NEGLIGENCE OF SMSC OR OTHERS; STRICT LIABILITY; BREACH OF WARRANTY; OR OTHERWISE; WHETHER OR NOT ANY REMEDY OF BUYER IS HELD TO HAVE FAILED OF ITS ESSENTIAL PURPOSE, AND WHETHER OR NOT SMSC HAS BEEN ADVISED OF THE POSSIBILITY OF SUCH DAMAGES.

General Description

The LAN89303AM is a full featured, 3 port 10/100 managed Ethernet switch designed for embedded applications where performance, flexibility, ease of integration and system cost control are required. The LAN89303AM combines all the functions of a 10/100 switch system, including the Switch Fabric, packet buffers, Buffer Manager, Media Access Controllers (MACs), PHY transceivers and serial management. The LAN89303AM complies with the IEEE 802.3 (full/half-duplex 10BASE-T and 100BASE-TX) Ethernet protocol specification and 802.1D/802.1Q network management protocol specifications, enabling compatibility with industry standard Ethernet and Fast Ethernet applications.

At the core of the device is the high performance, high efficiency 3 port Ethernet Switch Fabric. The Switch Fabric contains a 3 port VLAN layer 2 Switch Engine that supports untagged, VLAN tagged and priority tagged frames. The Switch Fabric provides an extensive feature set which includes spanning tree protocol support, multicast packet filtering and Quality of Service (QoS) packet prioritization by VLAN tag, destination address, port default value or DIFFSERV/TOS, allowing for a range of prioritization implementations. 32k of buffer RAM allows for the storage of multiple packets while forwarding operations are completed and a 512 entry forwarding table provides ample room for MAC address forwarding tables. Each port is allocated a cluster of 4 dynamic QoS queues which allow each queue size to grow and shrink with traffic, effectively utilizing all available memory. This memory is managed dynamically via the Buffer Manager block within the Switch Fabric. All aspects of the Switch Fabric are managed via the Switch Fabric configuration and status registers, which are indirectly accessible via the system control and status registers.

The LAN89303AM provides 3 switched ports. Each port is fully compliant with the IEEE 802.3 standard and all internal MACs and PHYs support full/half-duplex 10BASE-T and 100BASE-TX operation. The LAN89303AM provides 2 on-chip PHYs, 1 Virtual PHY and 3 MACs. The Virtual PHY and the third MAC are used to connect the Switch Fabric to an external MAC or PHY. In MAC mode, the device can be connected to an external PHY via the MII/Turbo MII interface. In PHY mode, the device can be connected to an external MAC via the MII/RMII/Turbo MII interface. All ports support automatic or manual full-duplex flow control or half-duplex backpressure (forced collision) flow control. 2K jumbo packet (2048 byte) support allows for oversized packet transfers, effectively increasing throughput while decreasing CPU load. All MAC and PHY related settings are fully configurable via their respective registers within the device.

The integrated I²C and SMI slave controllers allow for full serial management of the device via the integrated I²C or MII interface, respectively. The inclusion of these interfaces allows for greater flexibility in the incorporation of the device into various designs. It is this flexibility which allows the device to operate in 2 different modes and under various management conditions. In both MAC and PHY modes, the device can be SMI managed or I²C managed. This flexibility in management makes the LAN89303AM a candidate for virtually all switch applications.

The LAN89303AM contains an I²C master EEPROM controller for connection to an optional EEPROM. This allows for the storage and retrieval of static data. The internal EEPROM Loader can be optionally configured to automatically load stored configuration settings from the EEPROM into the device at reset. The I²C management slave and master EEPROM controller share common pins.

In addition to the primary functionality described above, the LAN89303AM provides additional features designed for extended functionality. These include a configurable 16-bit General Purpose Timer (GPT), a 32-bit 25MHz free running counter and 6-bit configurable GPIO/LED interface.

The LAN89303AM's performance, features and small size make it an ideal solution for applications in the automotive market. Targeted applications include interfaces for diagnostics, gateway services, in-vehicle engineering development, manufacturing testing and legislated inspections.



SMSC®

Three Port 10/100 Managed Ethernet Switch with MII/RMII for Automotive Applications

Block Diagram

Revision 1.2 (07-20-11)

PRODUCT PREVIEW

4

SMSC LAN89303AM

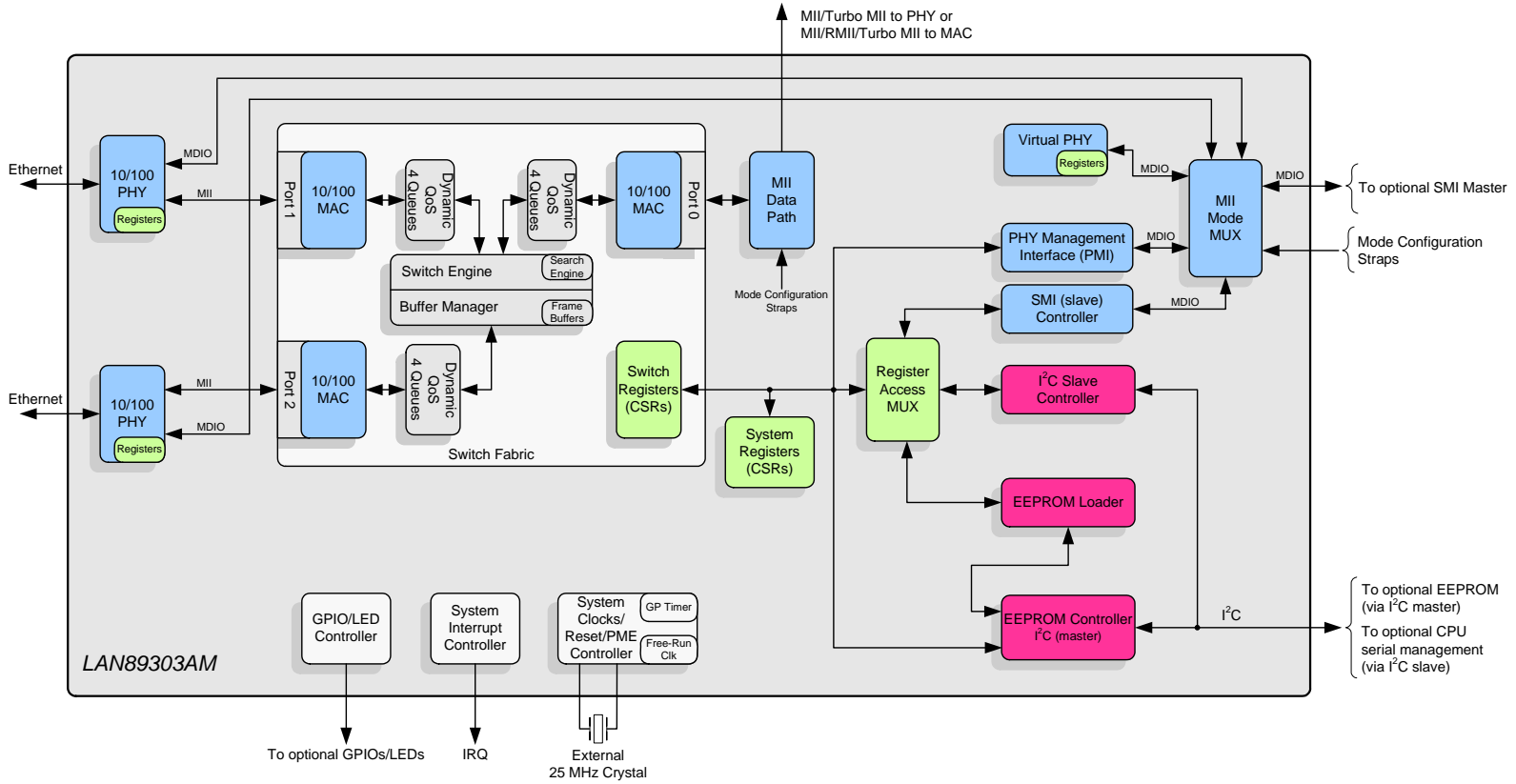

Figure 1 Internal Block Diagram

To optional GPIOs/LEDs
IRQ
External 25 MHz Crystal

To optional SMI Master
Mode Configuration Straps
To optional EEPROM (via I²C master)
To optional CPU serial management (via I²C slave)

Package Outline

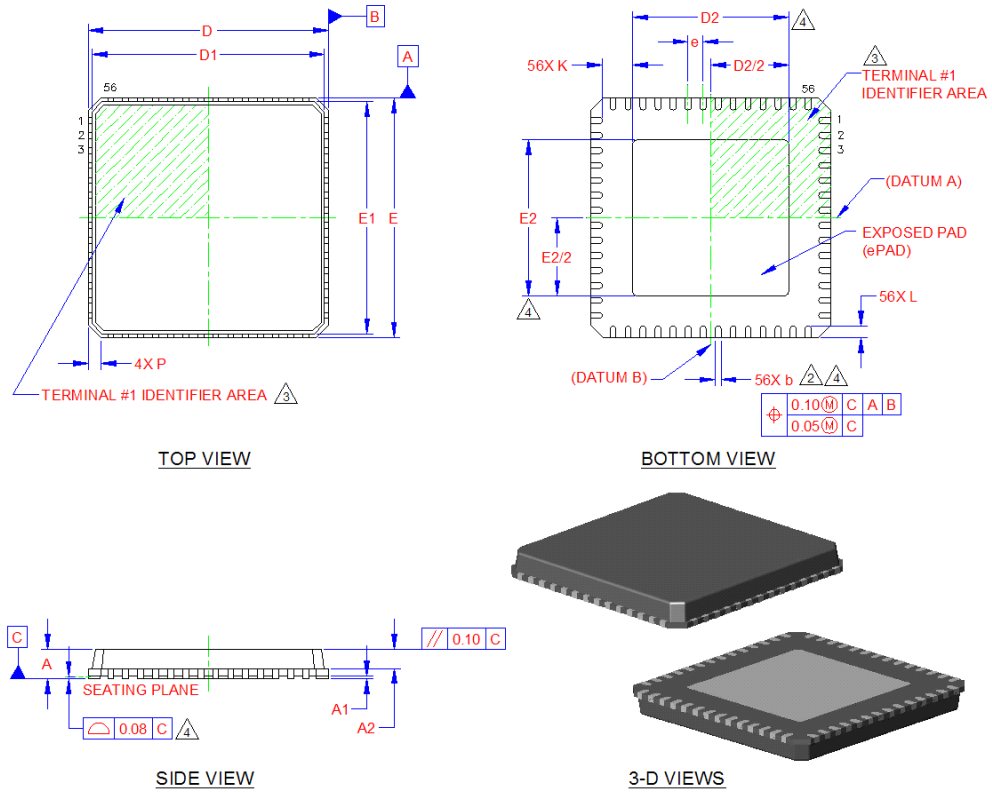

Figure 2 56-QFN Package Definition

**Table 1 56-QFN Dimensions**

	MIN	NOMINAL	MAX	REMARKS
A	0.80	0.85	0.90	Overall Package Height
A1	0	0.01	0.05	Standoff
A2	0.60	0.65	0.70	Mold Cap Thickness
D/E	7.90	8.00	8.10	X/Y Body Size
D1/E1	7.65	7.75	7.85	X/Y Mold Cap Size
D2/E2	5.10	5.20	5.30	X/Y Exposed Pad Size
L	0.30	0.40	0.50	Terminal Length
b	0.18	0.23	0.30	Terminal Width
K	-	1.00	-	Center Pad to Pin Clearance
P	0.24	0.42	0.60	Package Corner Chamfer
e	0.50 BSC			Terminal Pitch

Notes:

1. All dimensions are in millimeters unless otherwise noted.
2. Dimension "b" applies to plated terminals and is measured between 0.15 and 0.30mm from the terminal tip.
3. The pin 1 identifier may vary, but is always located within the zone indicated.
4. Bilateral coplanarity zone applies to the exposed pad and the perimeter terminals.



Further Information

For more information on SMSC automotive products, including integrated circuits, software, and MOST® development tools and modules, visit our web site: <http://www.sm-sc-ais.com>. Direct contact information is available at: <http://www.sm-sc-ais.com/offices>.

SMSC Europe GmbH

Bannwaldallee 48
D-76185 Karlsruhe
Germany

SMSC

80 Arkay Drive
Hauppauge, New York 11788
USA

Technical Support

Contact information for technical support is available at: <http://www.sm-sc-ais.com/contact>.