

THIS DOCUMENT IS THE PROPERTY OF KEYSTONE ELECTRONICS CORP. AND SHALL NOT BE REPRODUCED, DISTRIBUTED OR USED AS A BASIS FOR MANUFACTURE WITHOUT PRIOR WRITTEN PERMISSION FROM KEYSTONE ELECTRONICS CORP.

**MOUNTING PAD LAYOUT**

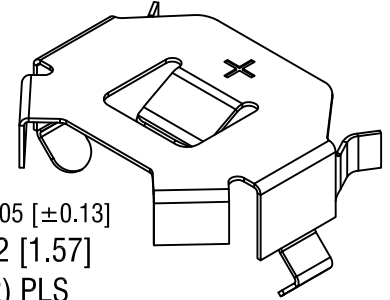

**SECTION A-A**

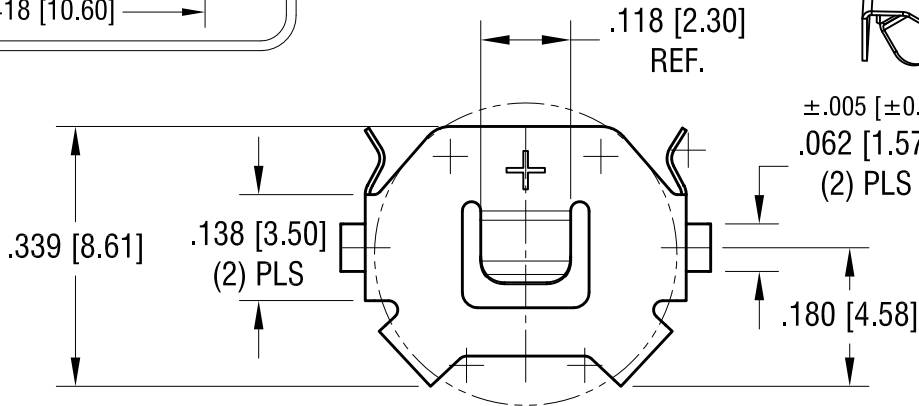
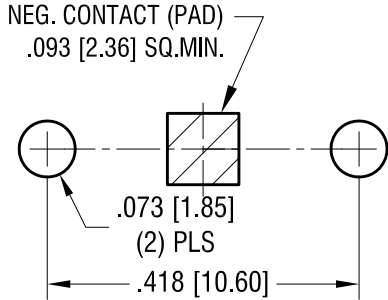
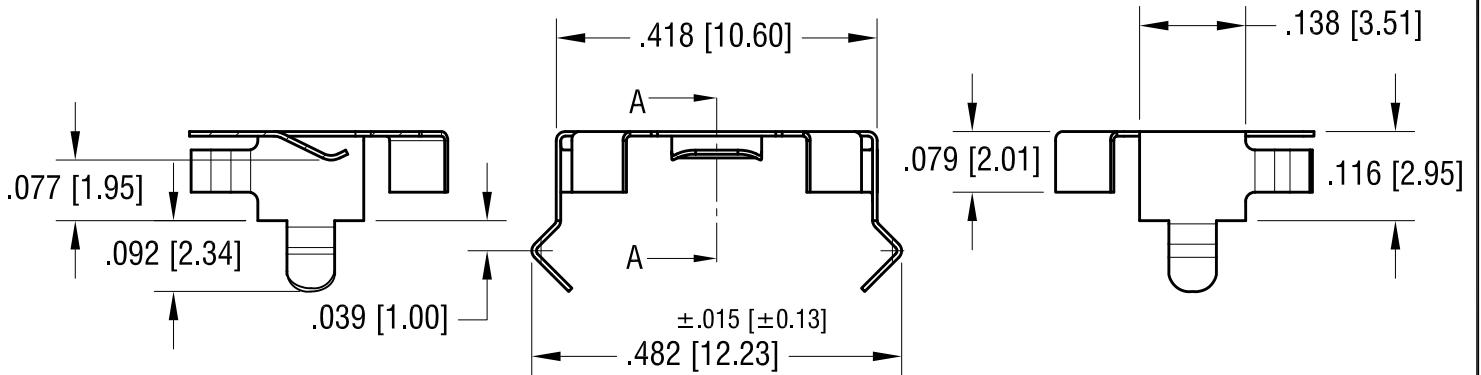

**KEYSTONE ELECTRONICS CORP.**

www.keyelco.com • ASTORIA, N.Y. 11105-2017 • Tel (718) 956-8900

PART NAME

10mm THM COIN CELL CLIP

MATERIAL

.006 [0.15] TH'K PHOSPHOR BRONZE

FINISH

TIN NICKEL PLATE

DRN BY

NT

DATE

9.20.10

APP'D

LN

SCALE

4X

2.27.12 CHANGE AS PER ECN 12-024

A

TOLERANCES INCH [MM]

DECIMAL ±.010 [±0.25]

ANGULAR ± 1°

UNLESS OTHERWISE SPECIFIED

CODE

C

DWG NO.

3031

DATE

DESCRIPTION

REV.