

Entube TE

Three Phase
Voltage Sensor

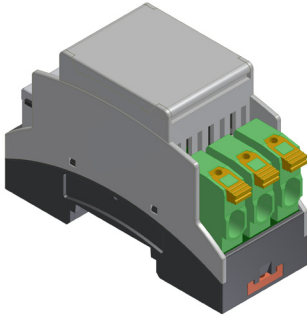

OVERVIEW

The Entube-TE series is designed for high quality three-phase measurements in a very compact form factor without need for power supplies. This series covers the ranges of $\pm 100V$, $\pm 200V$, $\pm 300V$, $\pm 400V$, $\pm 500V$, $\pm 750V$ and $\pm 1000V$, with up to 85kHz bandwidth and 0.2% accuracy. The Entube-TE sensor operates as a differential divider network with an anti-aliasing filter on its output. It generates a $\pm 5V$ or $\pm 10V$ scaled down version of the line-to-line and line-to-ground voltage on its input terminals. Depending on the software configuration, the sensor outputs phase-to-phase voltages for Delta configuration, or phase-to-ground for Wye configurations. This signal can then be processed by most computer based measurement platforms. One Entube-TE replaces 3 sensors, and only requires one cable for all three signals. This allows for very high channel densities, while delivering high performance for a low cost.

SPECIFICATION

Entube TE	100V	200V	300V	400V	500V	750V	1000V
Bandwidth (-3dB point)	85kHz		50kHz			25kHz	
Integrated sensor noise (Referenced to input)	< 30 μV	< 60 μV	< 100 μV	< 130 μV	< 170 μV	< 220 μV	< 290 μV
Gain (Using 10V standard output voltage)	10	20	30	40	50	75	100
Input Impedance	> 1 M Ω		> 2 M Ω			> 3 M Ω	
Line Output Impedance	50k Ω	25k Ω	33k Ω	25k Ω	20k Ω	20k Ω	15k Ω

HARDWARE DESCRIPTION

The Entube-TE is a differential voltage down-converter designed for 3-phase systems. It outputs all line-to-line and line-to-ground signal pairs. Delta or Wye measurements can be made depending on the input configuration of the digitizer being used (NRSE or Differential).

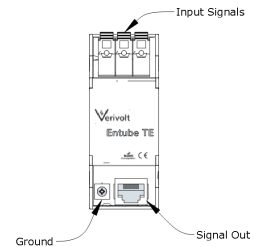

Signal Layout

The three input phases connect to the sensor via a Spring-cage, while the conditioned signals from the sensor come out on a standard Ethernet jack. The Entube-TE can be mounted anywhere between the signal source and the data acquisition system. A female-screw on the low voltage side of the sensor allows for DIN rail mounting, and serves as a safety ground.

A standard Ethernet cable is used to carry the conditioned signals from the sensor. The orange, brown and blue pairs carry phase voltages; the green connects to ground and DAQ reference. To avoid limiting the signal bandwidth and to eliminate cross-talk between pairs, a shielded STP Ethernet cable with a maximum length of 100m (330') should be used. This will keep good resolution beyond the 10th harmonic on a typical 60Hz system

Electrical	
Accuracy (percentage of reading)	$\pm 0.2\%$ ($\pm 0.05\%$ Typical)
Gain (Using 10V standard output voltage)	
Max total phase shift at 60Hz	< 0.05°
Common mode rejection	$\pm 2000V$
Withstanding differential mode surge voltage	$\pm 1000V$
Mechanical	
Mounting Type	DIN Rail
Connectivity (Connector for power in and signal out to/from the sensor)	RJ45 Ethernet jack
Outer Dimensions	1.4" x 1.4" x 4.5"
Weight	198 g (7.0 oz)

Integrated sensor noise (Referenced to input)	
Input-Output non-linearity	< 250 ppm
Output voltage	$\pm 10V$, $\pm 5V$
Gain temperature drift	± 50 ppm/°C
Differential input dynamic range	
Common mode rejection	52 dB
Power Supply Voltage	None
Output type	Single-ended signal
Output Offset Voltage	< $\pm 10\mu V$ (on $\pm 10V$ signal)
Environmental	
Operating temperature	- 25 to 70 °C
Storage temperature	- 40 to 80 °C

MERCHICAL DIMENSIONS

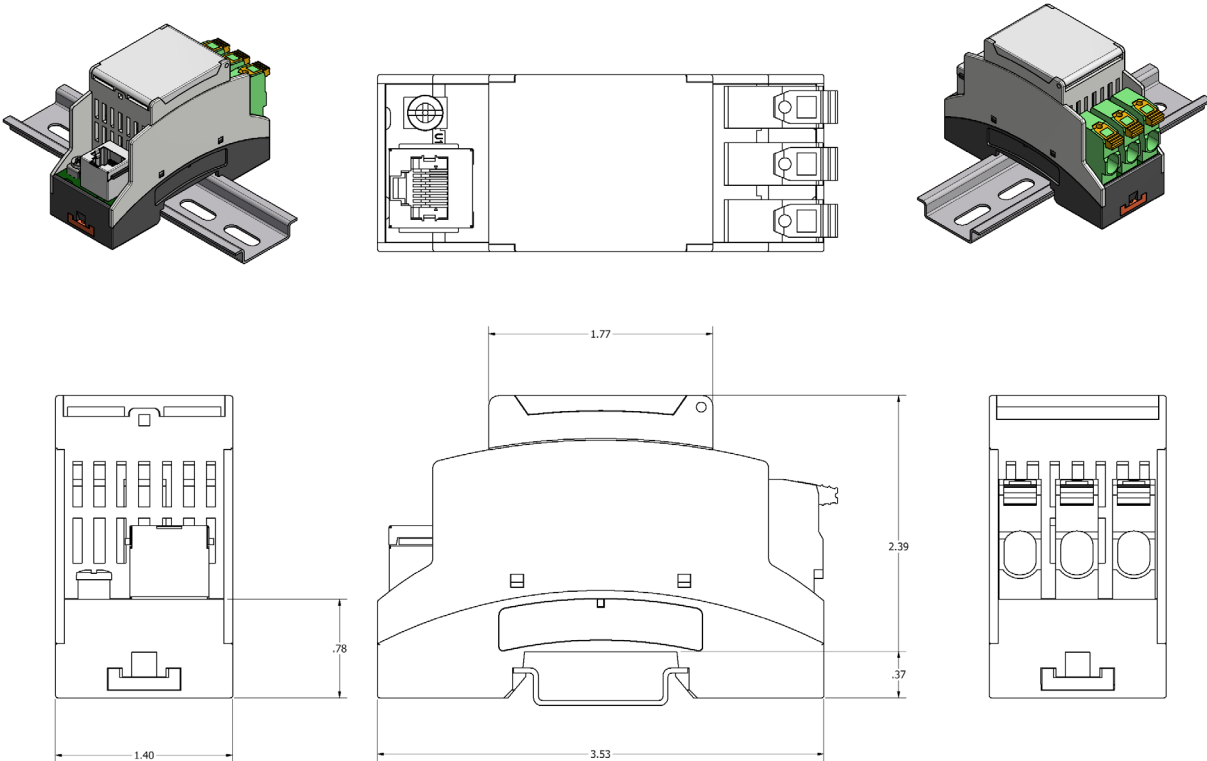

HARDWARE CONFIGURATION

A. Safely connect Data Acquisition ground to ground of sensor.

B. Securely connect one end of a RJ45 to the output terminals, and the other end to the inputs of your breakout board or data acquisition unit

C. Securely connect wire between the source of measurement and an available Entube TE's input screw terminal.

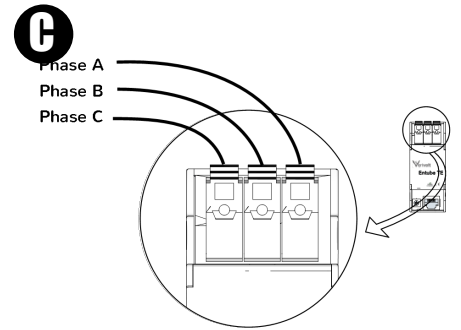
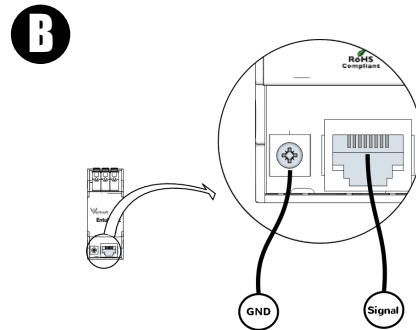
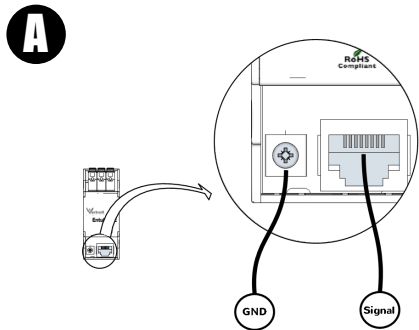

Standards and Certifications

- CE
- RoHS Compliant



DANGER

THIS SENSOR IS NOT A SAFETY DEVICE AND IS NOT INTENDED TO BE USED AS A SAFETY DEVICE. This sensor is designed only to detect and read certain data in an electronic manner and perform no use apart from that, specifically no safety-related use. This sensor product does not include self-checking redundant circuitry, and the failure of this sensor product could cause either an energized or de-energized output condition, which could result in death, serious bodily injury, or property damage.