

POWER MANAGEMENT

Description

The SC600 is a versatile charge pump designed for use in battery operated power supply applications. The wide input range is matched for Li-Ion battery applications. mAhXLife™ LED Drivers feature a fractional charge pump implementation with efficiency comparable to a switching regulator without costly inductors. Only two tiny ceramic capacitors are required, and the inductorless implementation provides a reduced-EMI solution. Patented low noise mode switching circuitry and constant output current allow the use of extremely small input and output capacitors.

The SC600 charge pump can be used for applications that require up to 120mA of output current with a 4.0V or 4.5V output. The 5.0V output version provides up to 60mA of output current.

mAhXLife™ LED drivers replace switched mode power supplies and provide comparable efficiency with less cost, area, noise, and complexity.

Typical Efficiency

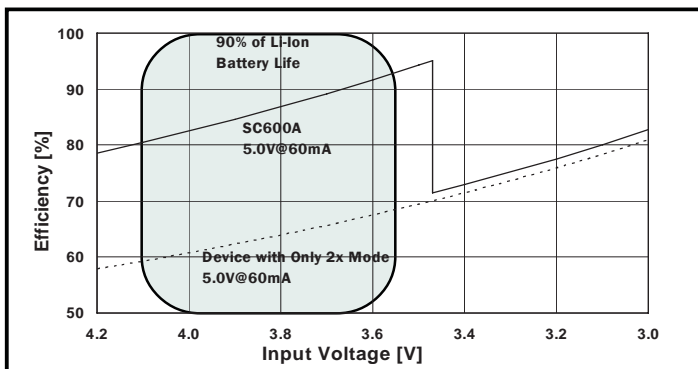

Features

- ◆ Small size - MLPD 10 lead 3x3mm or MSOP-10 package allows for a complete solution in .05 sq. in.
- ◆ Peak efficiency over 90% (extends battery life)
- ◆ Four component versions available
- ◆ 60mA versions available in 5.0V and 4.5V output
- ◆ 120mA versions available in 4.5V and 4.0V output
- ◆ Short-circuit and over-temperature protection
- ◆ Soft-start function
- ◆ Shutdown current <math><1\mu\text{A}</math>
- ◆ Selectable fixed frequencies of 8kHz, 32kHz, 262kHz and 650kHz
- ◆ Low input and output ripple
- ◆ Regulated to $\pm 5\%$
- ◆ Ease of use

Applications

- ◆ Cellular phones
- ◆ LED backlighting
- ◆ PDA power supplies
- ◆ Portable electronics
- ◆ Electronic books
- ◆ Handheld computers
- ◆ Wireless web appliances

Typical Application Circuit

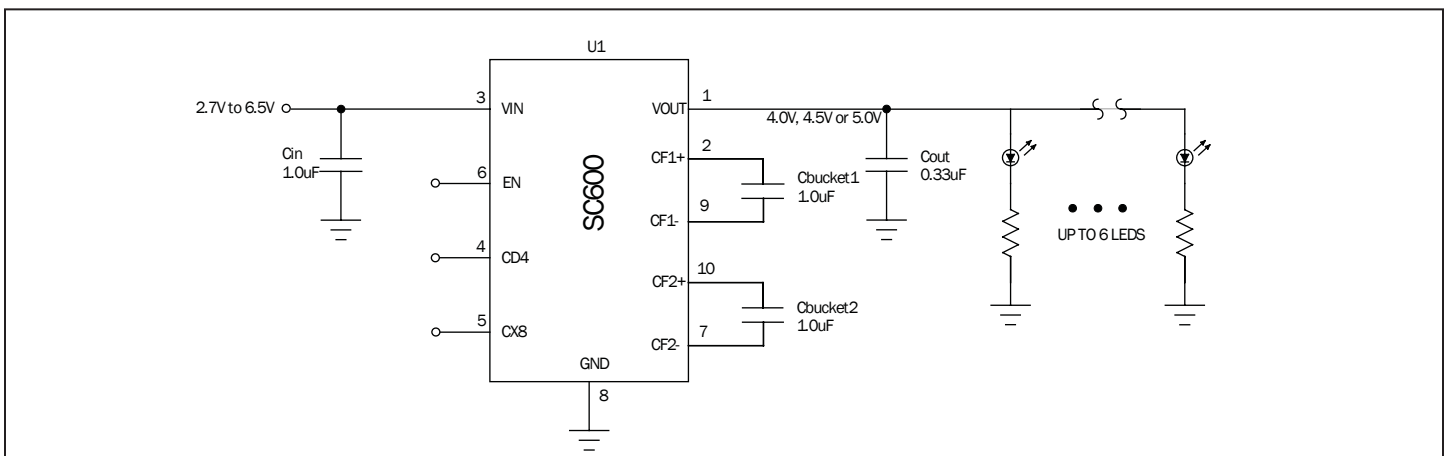

POWER MANAGEMENT
Absolute Maximum Ratings⁽¹⁾

Exceeding the specifications below may result in permanent damage to the device or device malfunction. Operation outside of the parameters specified in the Electrical Characteristics section is not implied.

Parameter	Symbol	Maximum	Units
Supply Voltage	V_{IN}	-0.3 to +7.0	V
Output Voltage	V_{OUT}	-0.3 to +7.0	V
V_{OUT} Short Circuit Duration	sc	Indefinite	s
Thermal Resistance, Junction to Ambient ⁽²⁾	θ_{JA}	49 (MLPD), 216 (MSOP)	°C/W
Operating Ambient Temperature Range	T_A	-40 to +85	°C
Junction Temperature Range	T_J	-40 to +150	°C
Storage Temperature Range	T_{STG}	-65 to +150	°C
Lead Temperature SC600_IMSTR	T_{LEAD}	260	°C
Lead Temperature SC600_IMSTR	T_{LEAD}	240	°C
IR Reflow Temperature SC600_IMLTR	T_{LEAD}	260	°C
IR Reflow Temperature SC600_IMLTR	T_{LEAD}	240	°C

Notes:

1) This device is ESD sensitive. Use of standard ESD handling precautions is required.

2) Calculated from package in still air, mounted to 3"x 4.5", 4 layer FR4 PCB with thermal vias under the exposed pad per JESD51 standards.

Electrical Characteristics

Unless otherwise specified: $T_A = -40^\circ\text{C}$ to $+85^\circ\text{C}$, $C_{IN} = C_{BUCKET} = 1.0\mu\text{F}$ (ESR = 0.1 Ω), $C_{OUT} = 1.0\mu\text{F}$ (ESR = 0.1 Ω), $V_{IN} = 2.85\text{V}$ to $5.5\text{V}^{(1)}$.

Parameter	Symbol	Conditions	Min	Typ	Max	Units
Input Supply Voltage	V_{IN}		2.5		6.5	V
Quiescent Current	I_Q	Freq. = 8kHz, $I_{OUT} = 0\text{mA}$, $V_{IN} = 3.7\text{V}$		230	380	μA
		Freq. = 32kHz, $I_{OUT} = 0\text{mA}$, $V_{IN} = 3.7\text{V}$		280	470	
		Freq. = 262kHz, $I_{OUT} = 0\text{mA}$, $V_{IN} = 3.7\text{V}$		800	1200	
		Freq. = 650kHz, $I_{OUT} = 0\text{mA}$, $V_{IN} = 3.7\text{V}$		1.6	2.5	mA
		Enable = 0				1
Output Voltage	V_{OUT}	Version A, Static Load Regulation Freq. = 262kHz or 650kHz ⁽²⁾ , $I_{OUT} = 0$ to 60mA	4.75	5.0	5.25	V
		Version B, Static Load Regulation Freq. = 262kHz or 650kHz ⁽²⁾ , $I_{OUT} = 0$ to 120mA	4.275	4.5	4.725	
		Version C, Static Load Regulation Freq. = 262kHz or 650kHz ⁽²⁾ , $I_{OUT} = 0$ to 60mA	4.275	4.5	4.725	
		Version D, Static Load Regulation Freq. = 262kHz or 650kHz ⁽²⁾ , $I_{OUT} = 0$ to 120mA	3.8	4.0	4.2	

POWER MANAGEMENT
Electrical Characteristics (Cont.)

Parameter	Symbol	Conditions	Min	Typ	Max	Units
Output Current	I_{OUT}	Freq. = 262kHz or 650kHz ⁽²⁾ ; Versions A & C			60	mA
		Freq. = 262kHz or 650kHz ⁽²⁾ ; Versions B & D			120	
		Freq. = 8kHz; Versions A & C			5	
		Freq. = 8kHz; Versions B & D			10	
		Freq. = 32kHz; Versions A & C			20	
		Freq. = 32kHz; Versions B & D			40	
Pump Frequency	f_{PUMP}	Enable = 1, CD4 = 0, CX8 = 0	-15%	32.768	+15%	kHz
		Enable = 1, CD4 = 1, CX8 = 0	-15%	8.192	+15%	
		Enable = 1, CD4 = 0, CX8 = 1	-13%	262.14	+15%	
		Enable = 1, CD4 = 1, CX8 = 1	-20%	650	+20%	
Frequency Mode Transition Time	T_{FMT}	Transition time from one frequency mode to any other frequency mode ⁽³⁾		1		Period
Short Circuit Current	I_{SC}	$V_{OUT} = 0V, I_{OUT} = I_{IN}$		180	600	mA
Input High Threshold	V_{IH}	All Input Pins (Enable, CD4, CX8)	1.3			V
Input Low Threshold	V_{IL}	All Input Pins (Enable, CD4, CX8)			0.4	V
Input High Current	I_{IH}	All Input Pins (Enable, CD4, CX8)			10	μA
Input Low Current	I_{IL}	All Input Pins (Enable, CD4, CX8)			10	μA
Mode Transition Voltage	V_{IN}	1.5x to 2x mode, Versions A & B	3.43	3.50	3.56	V
		2x to 1.5x mode, Versions A & B	3.48	3.58	3.64	V
		Hysteresis	30	80	180	mV
	V_{IN}	1.5x to 2x mode, Versions C & D	3.23	3.30	3.36	V
		2x to 1.5x mode, Versions C & D	3.33	3.40	3.46	V
		Hysteresis	40	100	180	mV
Power Efficiency from Battery to Regulated Charge Pump Output@262kHz	η	$V_{IN} = 3.60V, V_{OUT} = 5.0V, I_{OUT} = 60mA$		92		%
		$V_{IN} = 3.60V, V_{OUT} = 4.5V, I_{OUT} = 120mA$		83		%
Output Ripple Voltage	V_{PP}	Freq = 262kHz, $I_{OUT} = 60mA^{(2), (3)}$		25	45	mV

Notes:

- 1) Version C has an extended input voltage range of operation at $V_{IN} = 2.60V$ to $5.5V$.
- 2) 650kHz allows the use of a smaller bucket capacitor.
- 3) Guaranteed by design.
- 4) Peak-to-peak output ripple voltage with $C_{OUT} = C_{BUCKET} = 1\mu F$ and X5R dielectric.

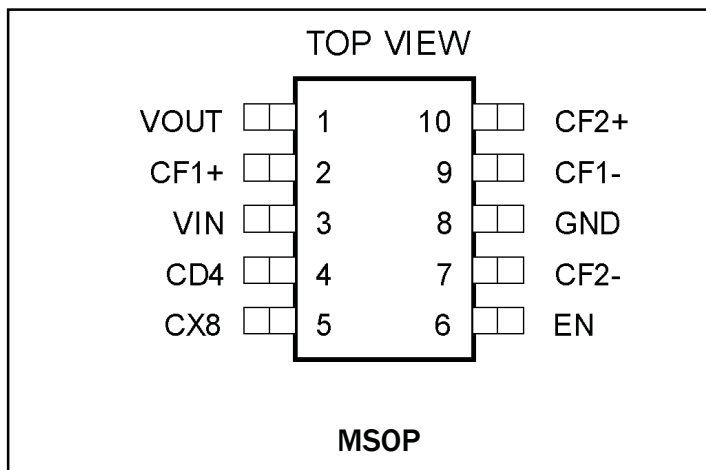
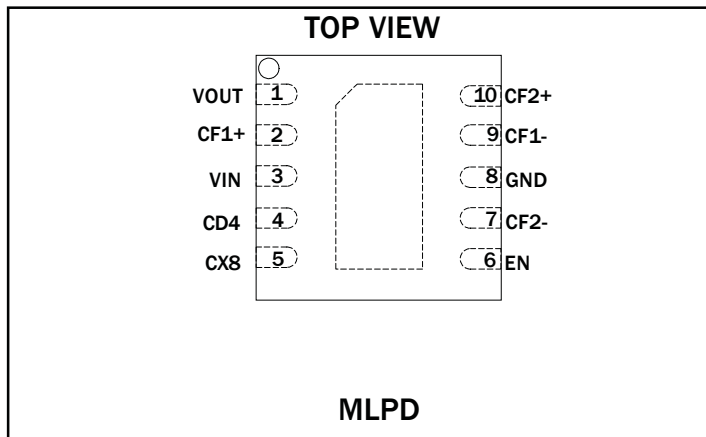
POWER MANAGEMENT
Pin Configuration

Ordering Information

Device ⁽¹⁾	Output	Package
SC600AIMSTR	60mA, 5.0V	MSOP-10
SC600BIMSTR	120mA, 4.5V	
SC600CIMSTR	60mA, 4.5V	
SC600DIMSTR	120mA, 4.0V	
SC600AIMSTRT	60mA, 5.0V	MSOP-10 Lead-Free ⁽²⁾
SC600BIMSTRT	120mA, 4.5V	
SC600CIMSTRT	60mA, 4.5V	
SC600DIMSTRT	120mA, 4.0V	
SC600AIMLTR	60mA, 5.0V	MLPD-10
SC600BIMLTR	120mA, 4.5V	
SC600CIMLTR	60mA, 4.5V	
SC600DIMLTR	120mA, 4.0V	
SC600AIMLTRT	60mA, 5.0V	MLPD-10 Lead-Free ⁽²⁾
SC600BIMLTRT	120mA, 4.5V	
SC600CIMLTRT	60mA, 4.5V	
SC600DIMLTRT	120mA, 4.0V	
SC600EVB	Evaluation Board [include the component part number when ordering]	

Notes:

- 1) Available in Tape and Reel only. A reel contains 2500 devices for MSOP and 3000 devices for the MLPD package.
- 2) This product is fully WEEE and RoHS compliant.

Component Selection

Output Voltage	Maximum Output Current from 0 to 60mA	Maximum Output Current from 60 to 120mA	Extended Range of 1.5 x Mode for Power Savings	Device
5.0V	X			SC600A
4.5V		X		SC600B
4.5V	X		X	SC600C
4.0V		X	X	SC600D

POWER MANAGEMENT

Pin Descriptions

Pin#	Pin Name	Pin Function
1	VOUT	Output voltage regulated to 5.0V, 4.5V, or 4.0V.
2	CF1+	Positive terminal of bucket capacitor 1.
3	VIN	Input voltage ranging from 2.5V to 6.5V.
4	CD4	Bits select the charge pump operating frequency from 8kHz, 32kHz, 262kHz, and 650kHz. Frequency selection is defined in Table 1 on page 9.
5	CX8	
6	EN	Active high enable. Bias current is less than 1µA when set low.
7	CF2-	Negative terminal of bucket capacitor 2.
8	GND	Ground.
9	CF1-	Negative terminal of buck capacitor 1.
10	CF2+	Positive terminal of bucket capacitor 2.

Block Diagram

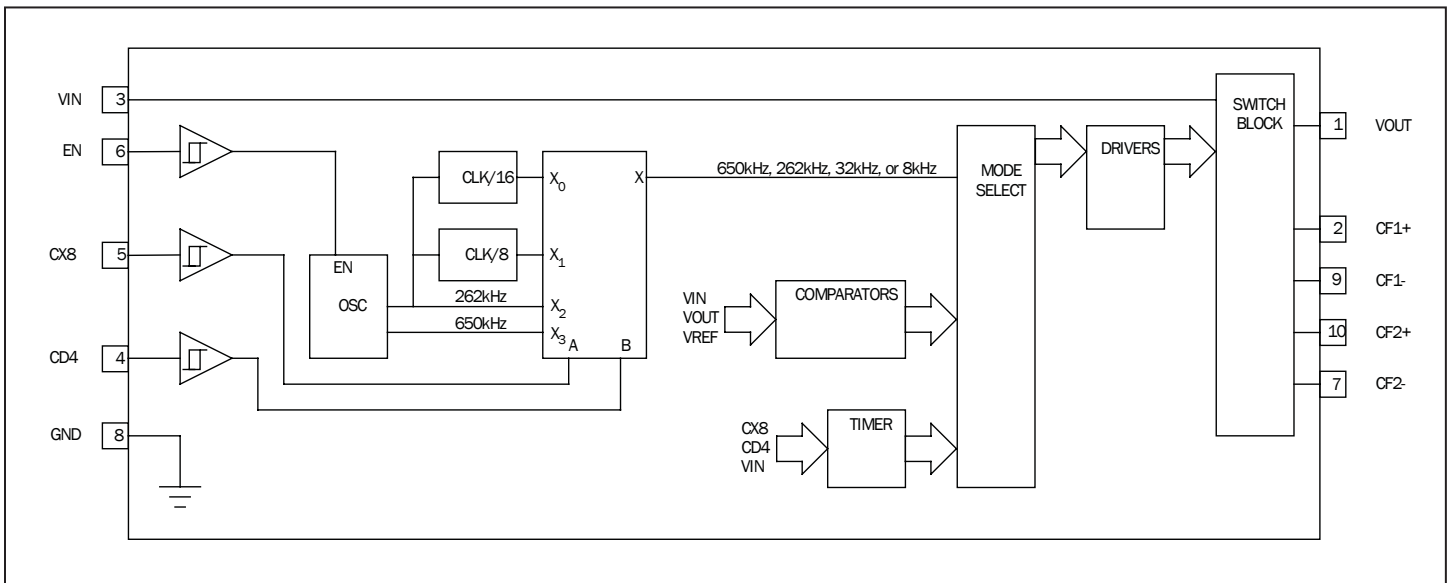

POWER MANAGEMENT

Marking Information - MLP-10

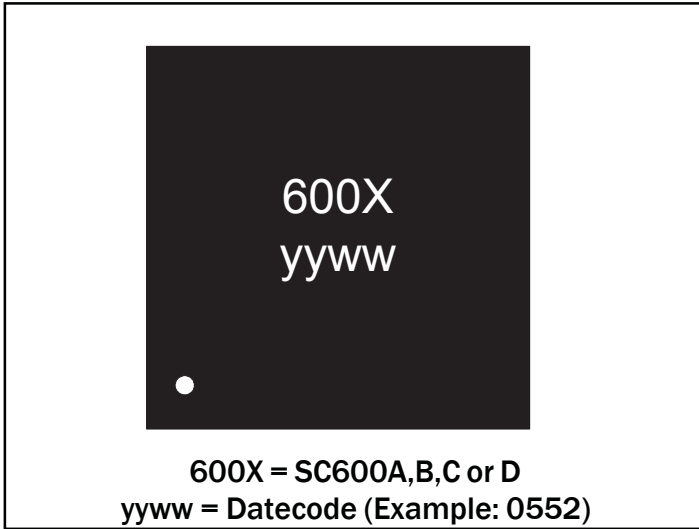

Marking Information - MSOP-10

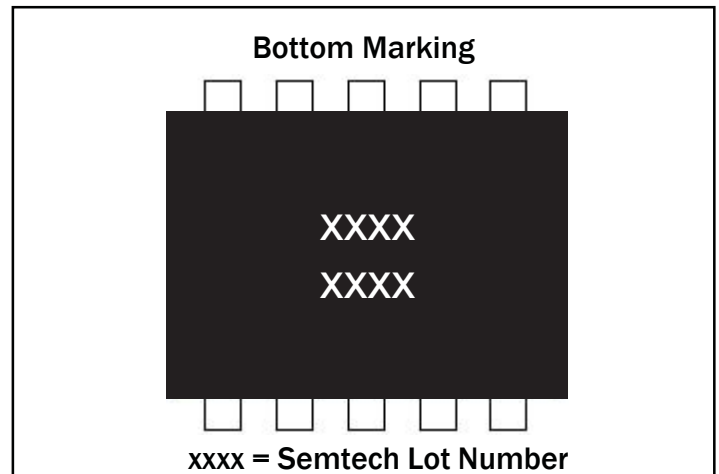
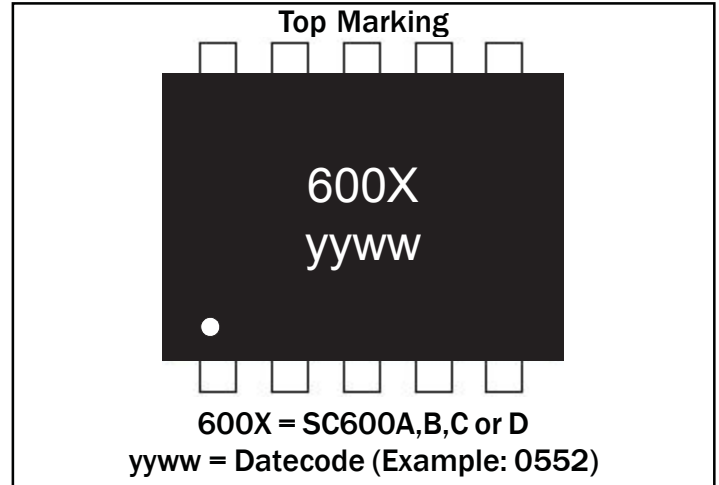

POWER MANAGEMENT

Applications Information

Regulated Fractional Charge Pump Operation

A fractional charge pump is a voltage converter which implements switched capacitor techniques to produce an output voltage that is one of several multiples of the input voltage. Regulated fractional charge pumps (also called charge pump regulators) use a linear regulator with various charge pump configurations to deliver a regulated output over a wide input voltage range. Regulated fractional charge pumps have improved efficiency over ordinary linear regulator and charge pump circuit combinations. The improved efficiency is achieved by implementing multiple charge pump configurations on one integrated circuit. The correct charge pump configuration is automatically selected to meet the regulation requirements at the best possible efficiency. The SC600 has three charge pump configurations (modes), which multiply the input voltage by 1x, 1.5x and 2x.

The charge pump configurations are implemented with two switched or 'bucket' capacitors plus the input and output capacitor. The bucket capacitors are configured for 1x mode at start-up to source current to the output capacitor and bring the output up quickly. The charge pump will begin switching in 1.5x mode. During normal operation, starting with a fully charged Li-Ion cell, the battery voltage will begin at about 4.1V. As the battery discharges and the voltage decays, the SC600 will eventually transition to 2x mode when the battery voltage is approximately 3.50V. Hysteresis is provided to prevent mode toggling. The output is prevented from exceeding 6.0V. This feature allows the use of 6.3V ceramic capacitors.

mAhXLIFE™ Advantage

The plot on page 1 shows the efficiency of the SC600A. An example of a 5.0V regulated charge pump doubler is plotted to demonstrate how effective the SC600's 1.5x mode is at improving efficiency when the input voltage is above 3.5V. Most of the Li-Ion battery life is above 3.5V where the SC600 achieves more than 20% higher efficiency compared to the 5.0V regulated charge pump doubler with only a 2x mode. Following the efficiency curve from left to right as the battery discharges, the SC600A 5.0V remains in 1.5x mode until 3.5V and then transitions to 2x mode.

Component Versions

There are four versions of the SC600. The component selection table on page 4 highlights the differences between the component types. The three basic differences between the component versions are in the output voltage, maximum output current capability, and the mode transition point.

The mode transition point is the value of input voltage at which the component will transition between 1.5x and 2x modes. 5.0V, 4.5V, and 4.0V versions are available. The SC600A (5.0V) is most efficient for applications that use up to 60mA. The SC600B (4.5V) and SC600C (4.5V) have different maximum output currents and mode transition points. The lower mode transition point of the SC600C allows it to remain in 1.5x mode longer for greater power savings.

The SC600B has higher output capability, up to 120mA, and SC600C is rated for 60mA. The SC600D (4.0V) is for applications using up to 120mA.

Start-Up Conditions

Typical start-up time is less than 50 μ s. Caution: The SC600 must be enabled while 650kHz or 262kHz is selected to prevent over-voltage during start-up.

LED Bias and Backlighting Applications

When using the SC600 for LED bias, note that the SC600C and SC600D require the same input power per unit of output current even though the SC600C is more efficient. Also, the SC600A will have the same input power as the SC600B though the SC600A is more efficient.

The following plots of Input Power vs. Input Voltage highlight the differences in application of the four component versions. To achieve the lowest possible input power, it is desirable for the charge pump to remain in 1.5x mode until the input voltage is as low as possible. The transition points from 1.5x to 2x are identified in the plot where the input power steps upward as the input voltage moves lower.

POWER MANAGEMENT

Applications Information (Cont.)

Input Power of SC600 A&C Output Current = 60mA

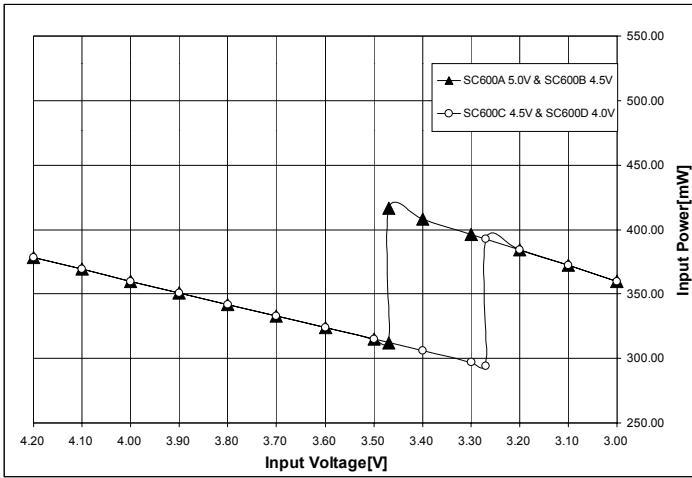

Input Power of SC600 B&D Output Current = 120mA

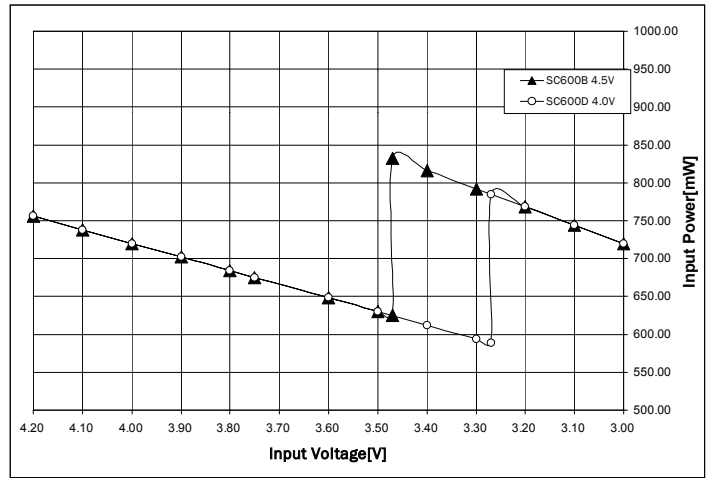

POWER MANAGEMENT

Applications Information (Cont.)

Brightness Control with PWM Input

Brightness control using a PWM input can be achieved with the application circuit below. Note that by connecting CX8 to the PWM signal the switching frequency is changed as the PWM signal changes. The charge pump operates at 262kHz during the on-time when there is a demand for

current, and then changes to 32kHz when there is no load current. This is done to save battery power by taking advantage of the lower 280µA quiescent current at 32kHz. The ripple voltage seen at the output is reasonable for LED applications, but the output capacitance can be increased to reduce the ripple if required. The sum of the LED currents for this circuit is 55mA during the on-time.

White LED Driver Circuit with PWM Brightness Control

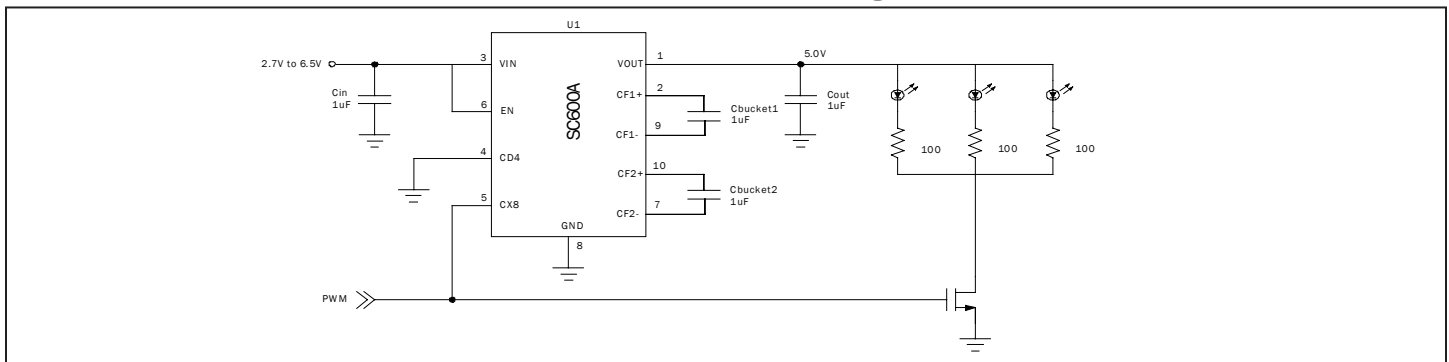

Voltage Waveforms for LED Driver Circuit

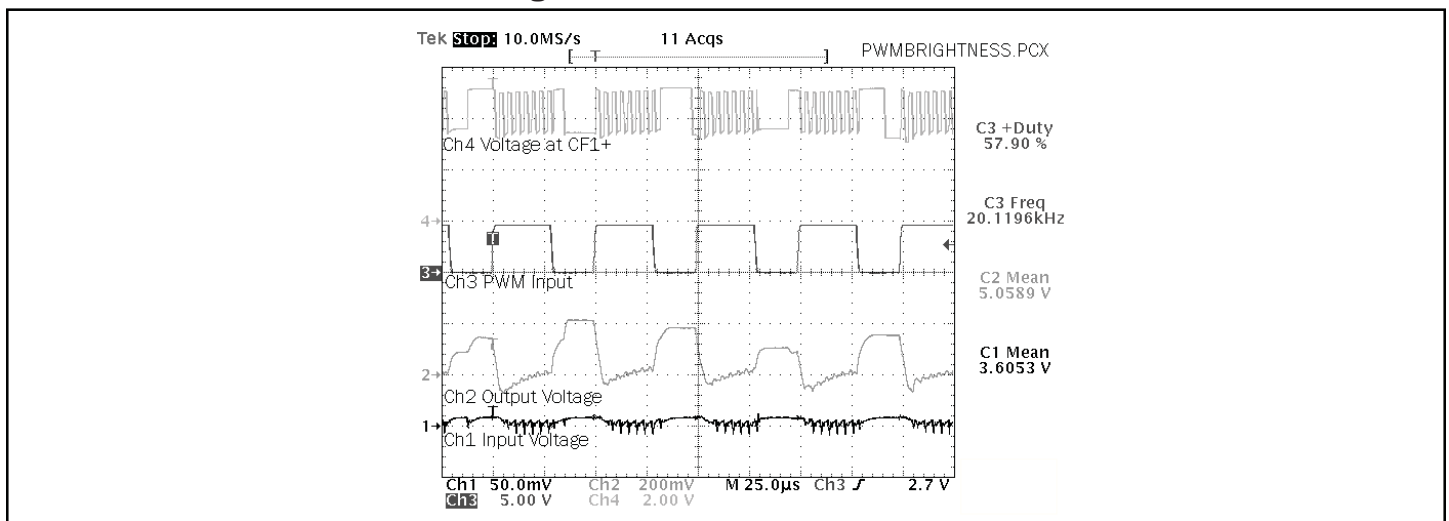

Ripple Voltage vs. Input Voltage

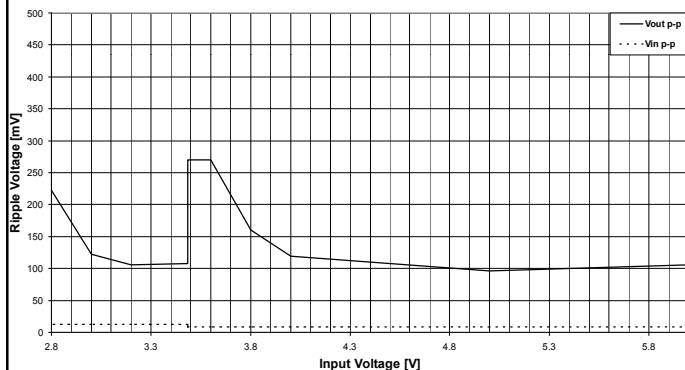

Battery Current vs. Input Voltage for Various Duty Cycles

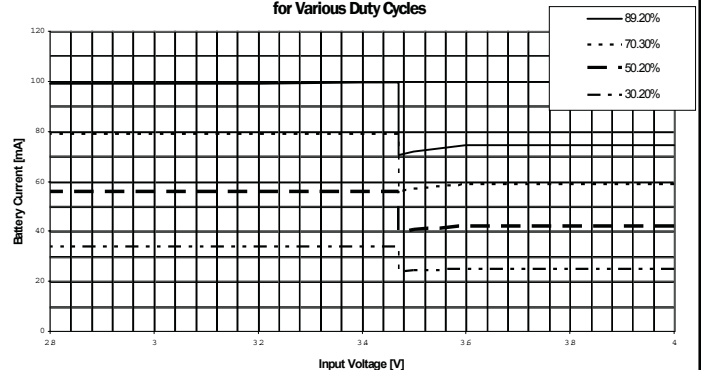

POWER MANAGEMENT
Applications Information (Cont.)
Comparison with Other Regulation Methods

In many instances, a charge pump regulator is the best choice for portable power applications. These regulators offer many advantages over switch mode regulators. A smaller bill of materials, less layout area, lower component height, less noise, no EMF, and less overall circuit cost are typical reasons to use this type of regulation. In some cases the efficiency of a charge pump regulator exceeds the efficiency of a switch mode regulator.

Inductors are often the largest and most expensive discrete component in a design. Because there are no inductors used in the SC600, cost, noise, layout area, as well as the the EMF associated with the inductor, are eliminated.

The SC600's fixed frequency harmonics are an advantage in portable communications equipment, such as cellular telephones. The SC600 has distinct frequencies of operation, so the harmonics are predictable. The harmonics are not fixed in a switch mode regulator.

Table 1 -Frequency Selection Logic

Switching Frequency	CX8	CD4
32kHz	0	0
8kHz	0	1
262kHz	1	0
650kHz	1	1

Table 2 -Ripple Performance

Part No.	Freq. [kHz]	I _{OUT} [mA]	Output Ripple [mVp-p] 1.5x mode	Ouput Ripple [mVp-p] 2x mode	C _{OUT} [μF]	C _{BUCKET} [μF]
SC600A 5.0V	8	5	65	15	1	1
	32	20	150	25	1	1
	262	60	25	20	1	1
	650	60	10	15	1	1
	650	60	20	25	0.33	1

Ripple Performance

Examples of the output ripple, charge pump frequency and capacitor size are listed in Table 2.

Switch mode regulators have harmonics which vary due to the pulse width modulation used to regulate the output. Varying harmonics can make it difficult to ensure acceptable noise performance over the entire operating range.

Many switch mode regulators have increased voltage ripple on the output during pulse skipping mode due to large periods of time when no current is supplied to the output. The SC600 supplies current to the output continuously, so the voltage ripple is less than a switch mode regulator, even with greatly reduced output capacitance. The SC600 delivers a continuous current to the output during 1x, 1.5x and 2x modes. Most of the battery life requires 1.5x mode.

Frequency Selection

CX8 and CD4 are frequency select inputs; input from a μP or other device may be used to change the charge pump frequency at any time (as shown in Table 1). The optimal frequency will depend upon the capacitor values, the load current, and the acceptable amount of output ripple. Lower frequencies will be more efficient, while higher frequencies will support higher output currents with lower ripple.

POWER MANAGEMENT
Applications Information (Cont.)
Table 2 -Ripple Performance (Cont.)

Part No.	Freq. [kHz]	I _{OUT} [mA]	Output Ripple [mVp-p] 1.5x mode	Ouput Ripple [mVp-p] 2x mode	C _{OUT} [μF]	C _{BUCKET} [μF]
SC600B⁽¹⁾ 4.5V	8	10	215	50	1	1
	32	40	300	90	1	1
	262	120	40	25	1	1
	650	120	15	25	1	1
	650	120	30	45	0.33	1
SC600D 4.0V	8	10	105	50	1	1
	32	40	240	45	1	1
	262	120	30	20	1	1
	650	120	11	20	1	1
	650	120	25	40	0.33	1

Note: (1) SC600C is very similar to SC600B.

Mode Transition Impedance

The mode transition impedance R_o refers to the output resistance of the charge pump before a transition to a stronger mode occurs. R_o is dependent upon the fractional charge pump, switching frequency, bucket capacitor value, bucket capacitor ESR, and the internal switch resistances.

R_o is proportional to, $\frac{1}{f \cdot C}$

R_o can be measured to verify a low transition impedance. Before measuring R_o , select the capacitors, set the operating frequency and a constant load current. Find the input voltage just before a weak to strong mode transition (i.e., 1.5x to 2x mode). Measure V_{IN} , V_{OUT} , and I_{OUT} before the transition.

R_o will be,

$$R_o = \frac{\text{mode} \cdot V_{IN} - V_{OUT}}{I_{OUT}}$$

A lower value of R_o will improve efficiency, so low ESR ceramic capacitors are required. An X7R or X5R dielectric is recommended. Y5V dielectric can require 2 to 3 times the rated value of an X7R dielectric for the same performance over the operating temperature range.

Efficiency

Efficiency for the SC600 is defined as,

$$\eta = \frac{V_O \cdot I_O}{V_{IN} \cdot (\text{mode} \cdot I_O + I_Q)}$$

POWER MANAGEMENT
Applications Information (Cont.)

where:

V_o = output voltage
 I_o = output current
 mode = 1.5x or 2x
 V_{IN} = input voltage
 I_o = quiescent current

(from Electrical Characteristics on page 2)

The mode may be identified by measuring input current and output current and calculating as mode = I_{IN}/I_{OUT} . Alternately, the mode can be identified by identifying the voltage at the bucket capacitor, CF1 with an oscilloscope.

Calculating Power Dissipation

The power dissipated by the SC600 is calculated as,

$$P_D = P_{IN} - P_{OUT}$$

$$P_D = V_{IN} \cdot (\text{mode } I_o + I_o) - V_o \cdot I_o$$

Suggested Capacitors

The following is a short list of some of the manufacturers and types of multi-layer ceramic capacitors that are suggested for the SC600.

Manufacturer	Part Number	Capacitance[μF]	Dielectric Type	EIA Package Size	Voltage Rating
AVX	0805ZC225K	2.2	X7R	0805	10V
AVX	0805ZC105K	1.0	X7R	0805	10V
AVX	0805ZC334K	0.33	X7R	0805	10V
Panasonic	ECJ2YB0J225K	2.2	X5R	0805	6.3V
Panasonic	ECJ2YB1A105	1.0	X7R	0805	10V
Panasonic	ECJ1VB0J105K	1.0	X5R	0402	6.3V
Panasonic	ECJ1VB0J334K	0.33	X5R	0603	6.3V
TDK	C1608X5R1A105	1.0	X5R	0603	10V
TDK	C1202Y5V1A106Z	1.0	X5R	0805	10V
TDK	C1608X5R1A334k	0.33	X5R	0603	10V

Short-Circuit and Over-Temperature Protection

The output current is limited to 600mA to protect against short-circuit conditions. Over-temperature protection is also provided.

Design and Layout Considerations

The layout example on page 15 uses the 1206 case size for the capacitors, so a smaller layout area is possible. The bucket capacitors and the SC600 are on the same side of the card. To minimize trace inductance, traces are short and wide with no vias to the bucket capacitors. The input and output caps are on the bottom side directly under the SC600 and vias are used to connect directly to copper shapes used for the input and output. The input and output capacitors and Pin 8 should be connected to ground very near the SC600.

POWER MANAGEMENT

Typical Characteristics

Load Regulation, $V_{IN} = 3.6V$, Freq. = 650kHz

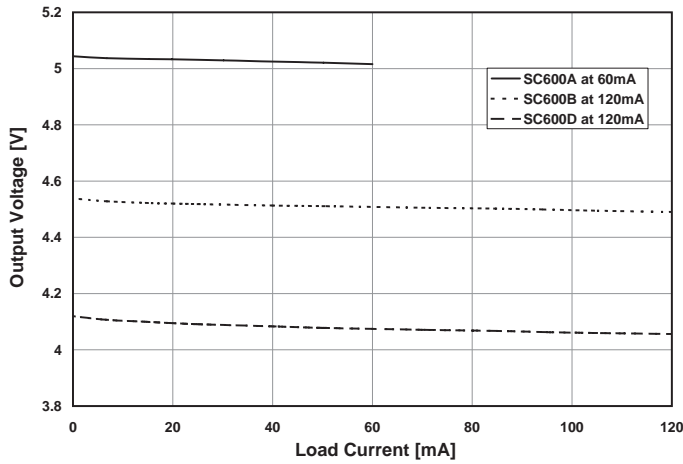

Line Regulation, Freq. = 650kHz

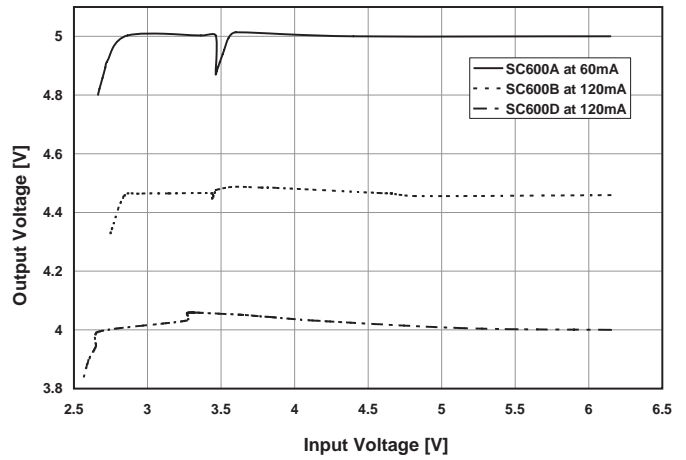

Efficiency vs. Output Current, $V_{IN} = 3.6V$, Freq. = 650kHz

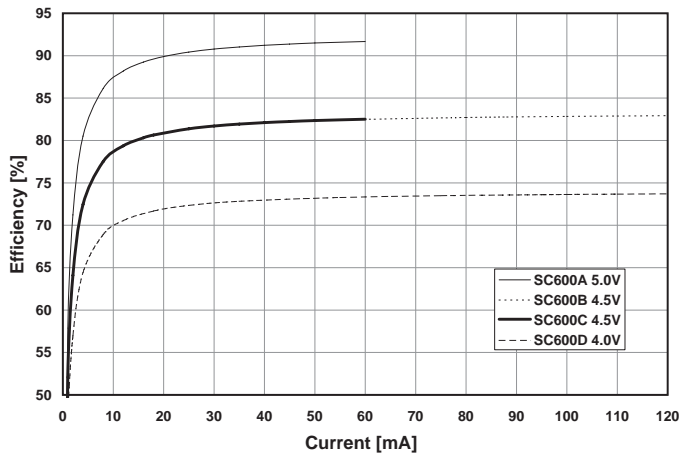

Start-Up Conditions for 5.0V Output

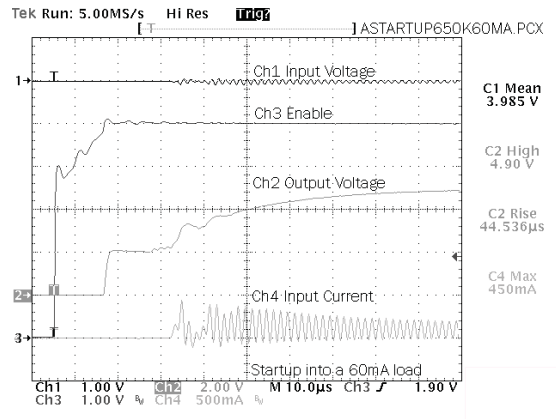

Ripple Voltage

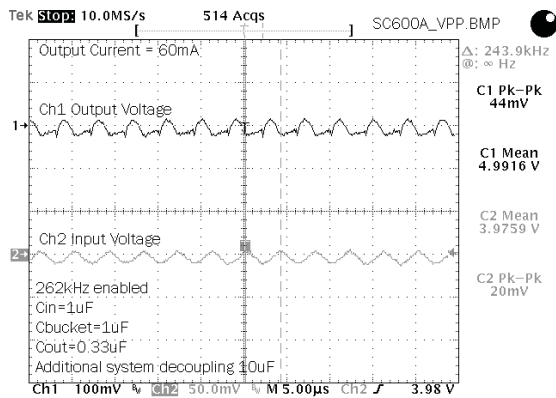

Start-Up Conditions for 4.0V Output

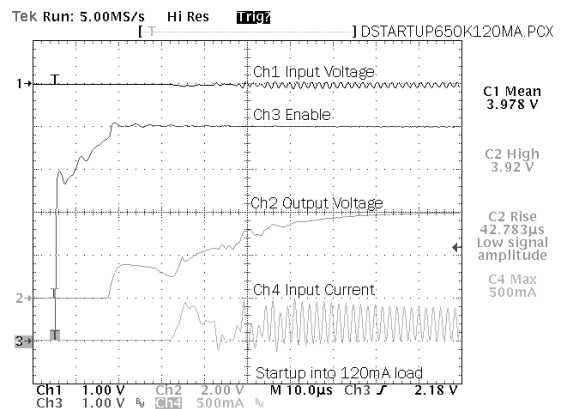

POWER MANAGEMENT

Typical Characteristics (Cont.)

Efficiency vs. Input Voltage for B and C Version

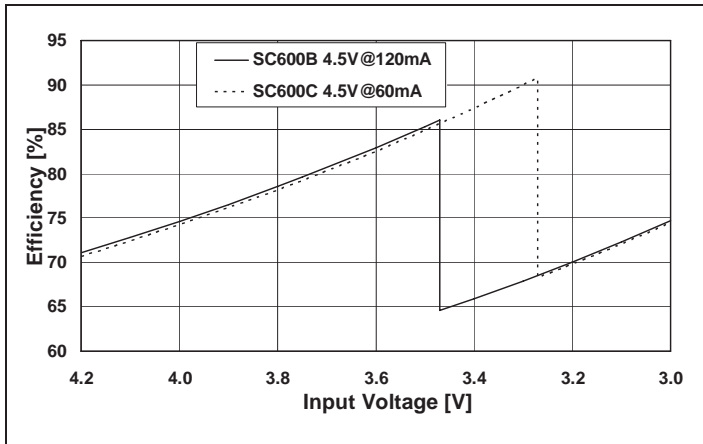

Efficiency vs. Input Voltage for A and D Version

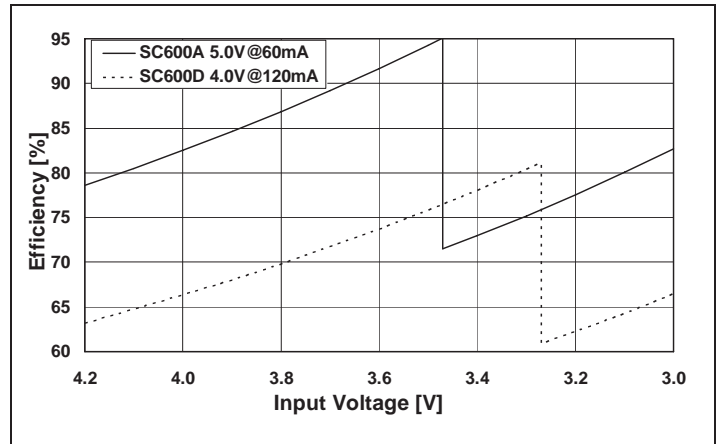

Evaluation Board Schematic

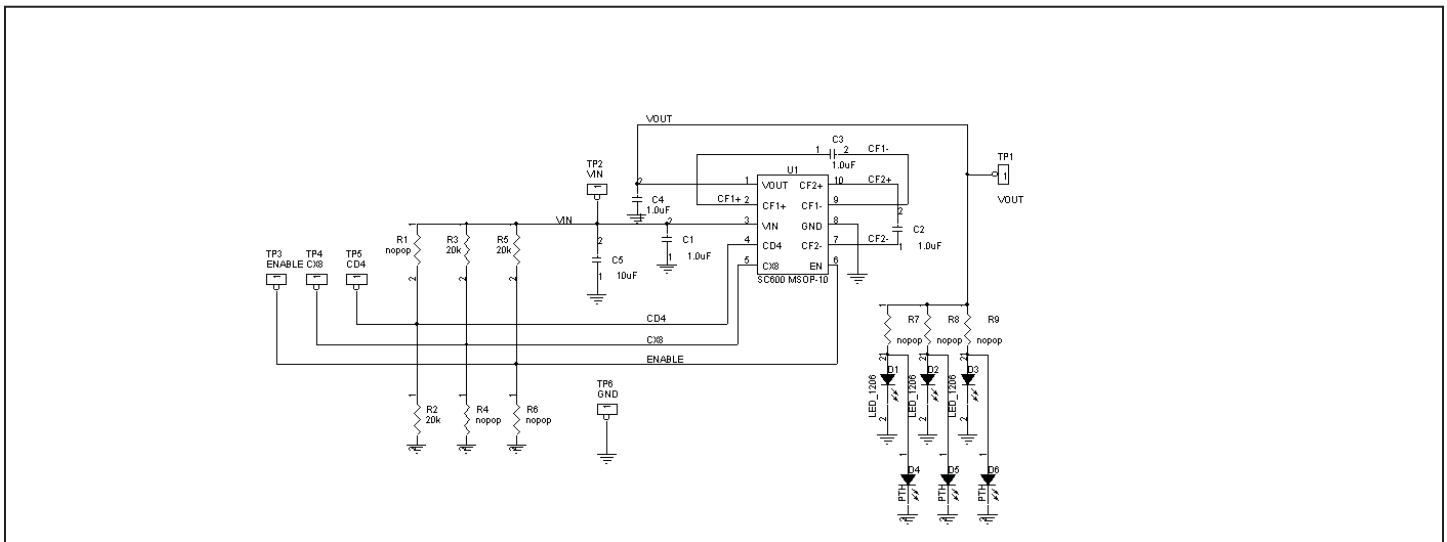

Evaluation Board Bill of Materials

Reference	Value	Comment
U1	SC600	MSOP-10 or MLPD-10 lead 3x3mm
C1, C2, C3, C4	1.0μF	Ceramic, low ESR type
C5	10μF	This extra capacitor supports usage of long power leads from a benchtop supply
R7, R8, R9	-	Add limiting resistors to meet the requirements of the application
D1, D2, D3	-	Add white or blue LEDs to meet the requirements of the applicaton on SMT pads
D4, D5, D6	-	Add white or blue LEDs to meet the requirements of the application on PTH pads

POWER MANAGEMENT

Evaluation Board Gerber Plots

Top View

Bottom View

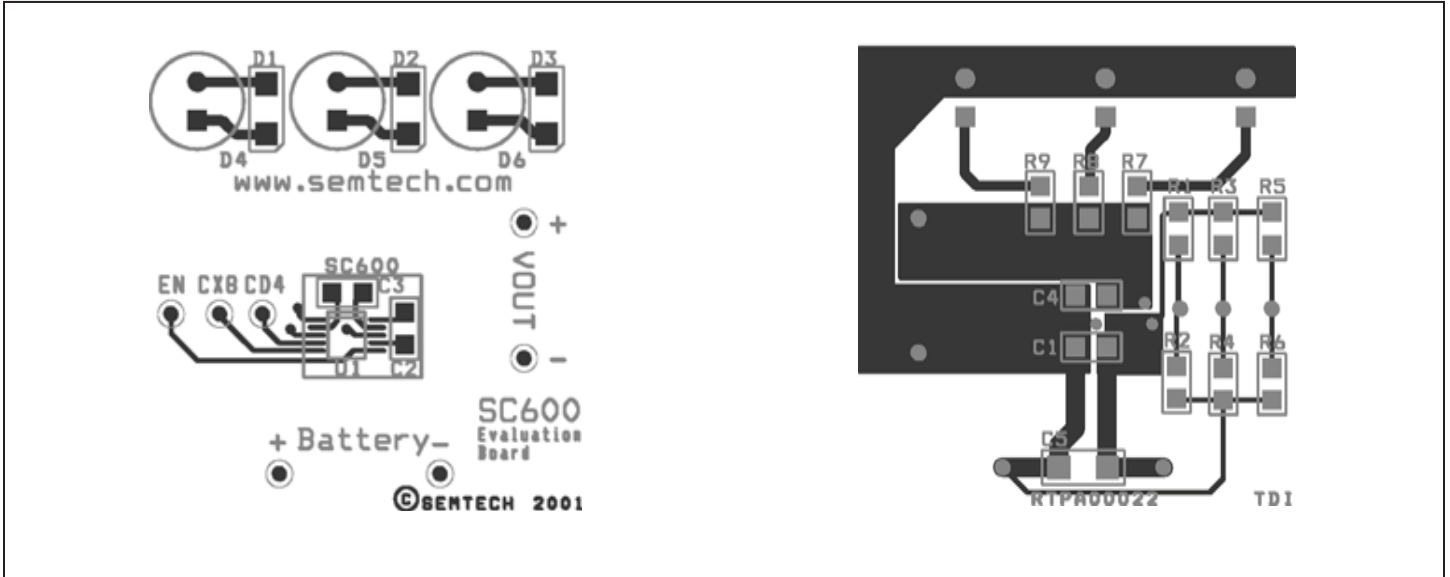

POWER MANAGEMENT

Outline Drawing - MSOP-10

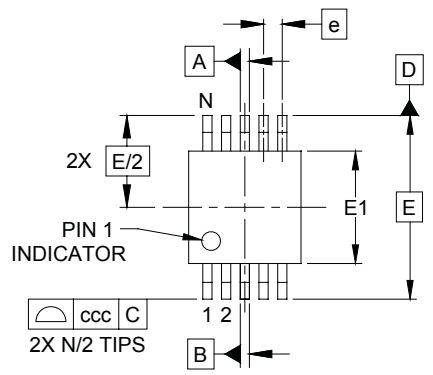

DIM	INCHES			MILLIMETERS		
	MIN	NOM	MAX	MIN	NOM	MAX
A	-	-	.043	-	-	1.10
A1	.000	-	.006	0.00	-	0.15
A2	.030	-	.037	0.75	-	0.95
b	.007	-	.011	0.17	-	0.27
c	.003	-	.009	0.08	-	0.23
D	.114	.118	.122	2.90	3.00	3.10
E1	.114	.118	.122	2.90	3.00	3.10
E	.193 BSC			4.90 BSC		
e	.020 BSC			0.50 BSC		
L	.016	.024	.032	0.40	0.60	0.80
L1	(.037)			(.95)		
N	10			10		
θ1	0°	-	8°	0°	-	8°
aaa	.004			0.10		
bbb	.003			0.08		
ccc	.010			0.25		

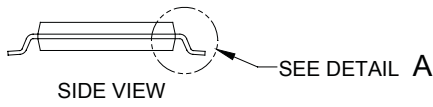
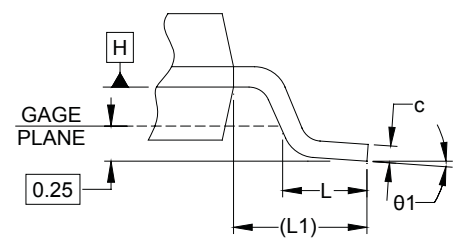
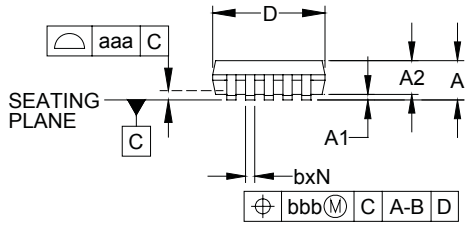

- NOTES:
1. CONTROLLING DIMENSIONS ARE IN MILLIMETERS (ANGLES IN DEGREES).
 2. DATUMS \square -A- AND \square -B- TO BE DETERMINED AT DATUM PLANE \square -H-
 3. DIMENSIONS "E1" AND "D" DO NOT INCLUDE MOLD FLASH, PROTRUSIONS OR GATE BURRS.
 4. REFERENCE JEDEC STD MO-187, VARIATION BA.

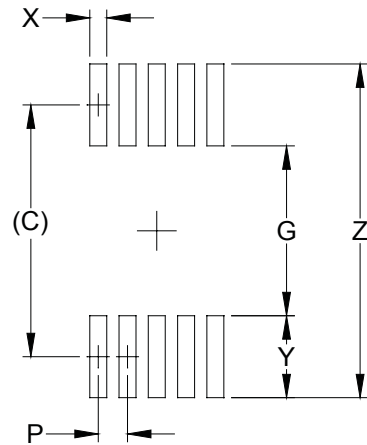
POWER MANAGEMENT
Land Pattern - MSOP-10

DIMENSIONS		
DIM	INCHES	MILLIMETERS
C	(.161)	(4.10)
G	.098	2.50
P	.020	0.50
X	.011	0.30
Y	.063	1.60
Z	.224	5.70

NOTES:

1. THIS LAND PATTERN IS FOR REFERENCE PURPOSES ONLY. CONSULT YOUR MANUFACTURING GROUP TO ENSURE YOUR COMPANY'S MANUFACTURING GUIDELINES ARE MET.

POWER MANAGEMENT

Outline Drawing - MLPD-10

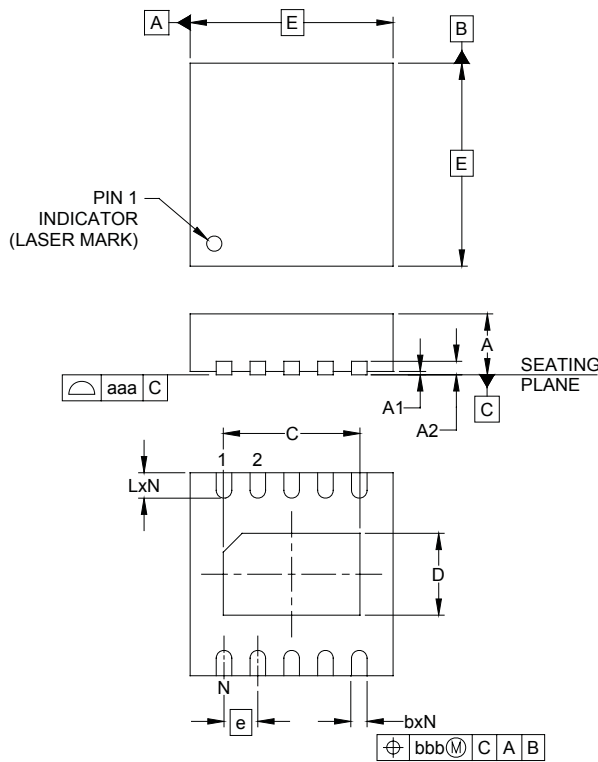

DIM	INCHES			MILLIMETERS		
	MIN	NOM	MAX	MIN	NOM	MAX
A	.031	-	.039	0.80	-	1.00
A1	.000	-	.002	0.00	-	0.05
A2	-	(.008)	-	-	(0.20)	-
b	.007	.009	.011	0.18	0.23	0.30
C	.074	.079	.083	1.87	2.02	2.12
D	.042	.048	.052	1.06	1.21	1.31
E	.114	.118	.122	2.90	3.00	3.10
e	.020 BSC			0.50 BSC		
L	.012	.016	.020	0.30	0.40	0.50
N	10			10		
aaa	.003			0.08		
bbb	.004			0.10		

NOTES:

1. CONTROLLING DIMENSIONS ARE IN MILLIMETERS (ANGLES IN DEGREES).
2. COPLANARITY APPLIES TO THE EXPOSED PAD AS WELL AS TERMINALS.

POWER MANAGEMENT

Land Pattern - MLPD-10

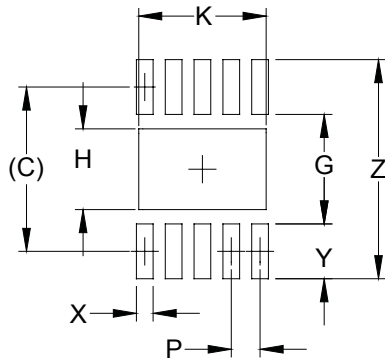

DIMENSIONS		
DIM	INCHES	MILLIMETERS
C	(.112)	(2.85)
G	.075	1.90
H	.055	1.40
K	.087	2.20
P	.020	0.50
X	.012	0.30
Y	.037	0.95
Z	.150	3.80

NOTES:

1. THIS LAND PATTERN IS FOR REFERENCE PURPOSES ONLY. CONSULT YOUR MANUFACTURING GROUP TO ENSURE YOUR COMPANY'S MANUFACTURING GUIDELINES ARE MET.

Contact Information

Semtech Corporation
 Power Management Products Division
 200 Flynn Road, Camarillo, CA 93012
 Phone: (805) 498-2111 FAX (805) 498-3804