

REVISIONS

NO.	DATE	DESCRIPTION
1	01/00	REVISIONS
2	01/00	REVISIONS
3	01/00	REVISIONS
4	01/00	REVISIONS
5	01/00	REVISIONS
6	01/00	REVISIONS
7	01/00	REVISIONS

- △ HOUSING MATERIAL: LIQUID CRYSTAL POLYMER.  
COLOR: NATURAL.
- △ CONTACT MATERIAL: PHOSPHOR BRONZE.
- △ CONTACT FINISH:(B)  
UNDERPLATE (ENTIRE CONTACT):  
0.0008 MIN MATTE TIN PER ASTM B 545 OVER UNDERPLATE.  
0.0008 MIN MATTE TIN PER ASTM B 545 OVER UNDERPLATE.  
LUBRICATION (MIN. MATING SURFACES):  
SURFACE CONDITIONER AFTER PLATING.
- △ PART MARKING, LOCATED APPROXIMATELY AS SHOWN.
- 5. SEE SHEET 2 FOR SEQUENCING CHARTS.
- △ DIMENSION APPLIES WHEN SEATED ON PRINTED CIRCUIT BOARD.

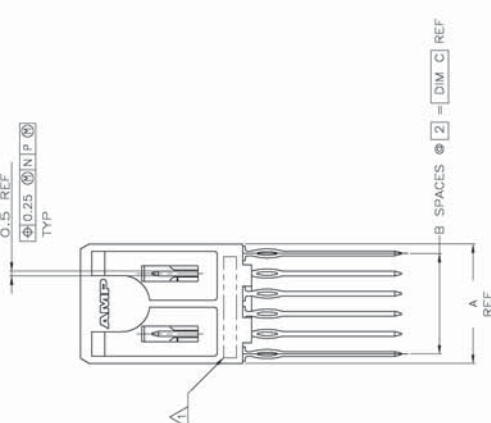
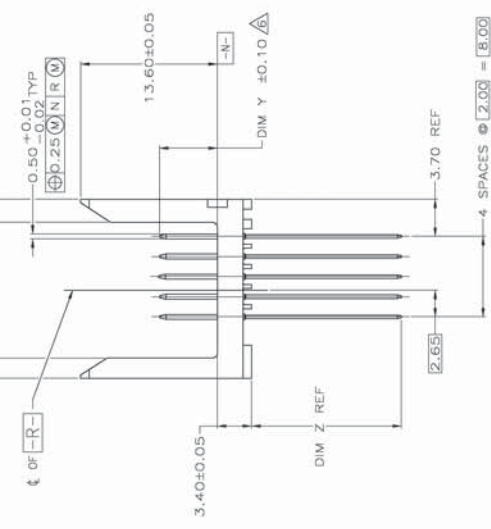
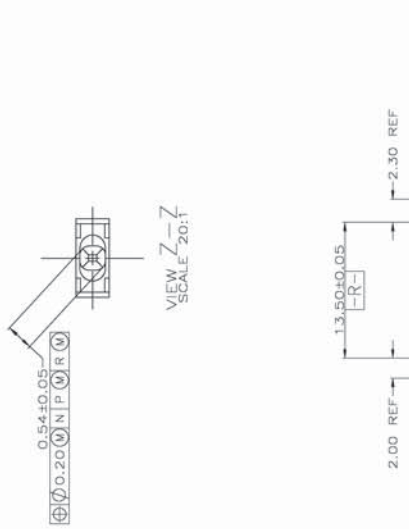

5223117-1 AS SHOWN

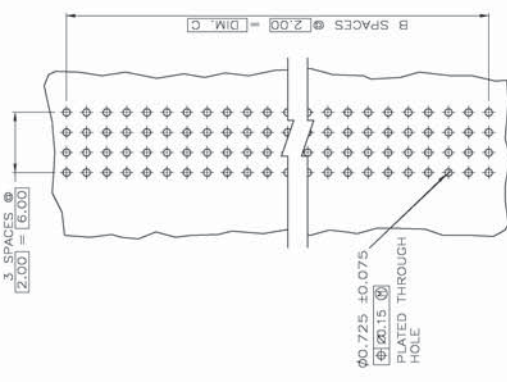
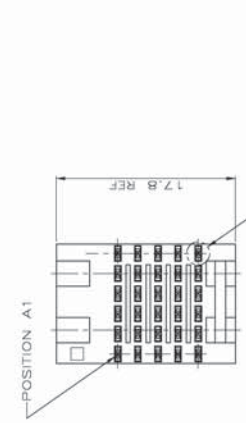

RECOMMENDED CIRCUIT PATTERN  
 PER IPC-D300 TYPE II, CLASS C  
 (COMPONENT SIDE)

NO.	DATE	DESCRIPTION	NO. OF SIGNAL POSN.	FINISH	PART NUMBER
260	1/30	1.31.88	350	A	1-5223117-1
10	5	11.88	30	A	5223117-1
C	B	A			

THIS DRAWING IS A CONTROLLED DOCUMENT.

DESIGNED BY: J. W. H. / J. W. H.  
 DRAWN BY: J. W. H. / J. W. H.  
 CHECKED BY: M. J. H. / M. J. H.  
 APPROVED BY: M. J. H. / M. J. H.

DATE: 01/00

SCALE: 20:1

PROJECT: TELCORDIA

PART NUMBER: 5223117-1

REVISED BY: J. W. H. / J. W. H.

DATE: 01/00

CUSTOMER DRAWING: 100779-5223117

Sheet 4.1 of 4

