

TSH-1XX-XX-XX-DX-XX

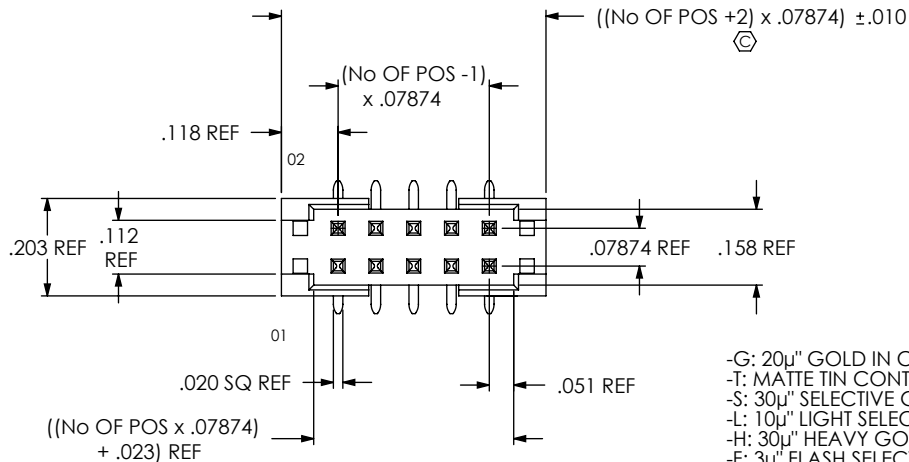

FIG 1

TSH-105-01-XX-DV SHOWN

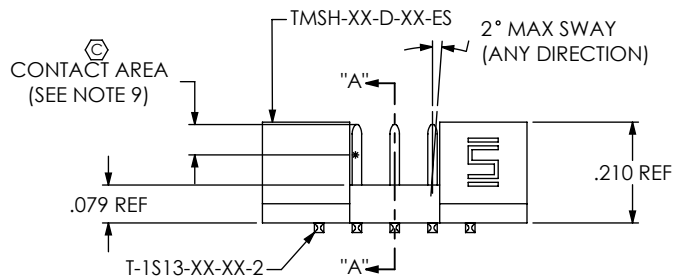
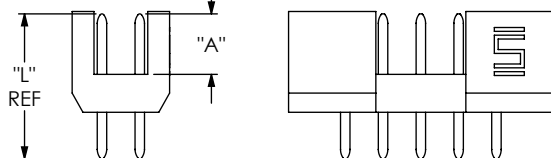

FIG 2

TSH-105-01-XX-D SHOWN



NOTES:

1. Ⓢ REPRESENTS A CRITICAL DIMENSION.
2. COPLANARITY TO BE WITHIN .0060.
3. BURR ALLOWANCE: .0015 MAX.
4. MAXIMUM CUT FLASH: .020.
5. MINIMUM PUSHOUT FORCE: 1.0 LB.
6. MAXIMUM ALLOWABLE BOW: .002 INCH/INCH AFTER ASSEMBLY.
7. MEASURED AT BEND RADIUS, NOT AT TIP OF PIN.
8. ALL POSITIONS AND ALL OPTIONS TO BE TUBED.
9. GOLD PLATING TO BE ON POST, TIN PLATING ON TAIL (ONLY APPLIES TO SELECTIVE PLATING OPTIONS).
10. SURFACE MOUNT STYLE -05: TAILS TO BE SHEARED TO ACHIEVE DIM.
11. PRINT CREATED FROM TMSH-ASM REVISION E. SEE TMSH-ASM FOR REVISION HISTORY.
12. SEE TSH-1XX-XX-X-XX-XX FOR -DH & -RA ROW SPECIFICATIONS.
13. ORIENTATE PINS TO REDUCE THE NUMBER OF BANDOLIERS MARKS IN THE POST AREA. (SEE TABLE 2).
14. DUE TO THE HIGH AMOUNT OF INSERTION FORCE NEEDED, THE -LC OPTION IS NOT COMPATIBLE WITH AUTO PLACEMENT. SAMTEC RECOMMENDS MANUAL PLACEMENT FOR ALL ASSEMBLIES WITH THE -LC OPTION.

No OF POSITIONS  
-05 THRU -48  
(PER ROW)

LEAD STYLE

- 01: .126 (USE T-1S13-07-XX-2)
- 04: .075 (USE T-1S13-04-XX-2)
- 05: .065 (USE T-1S13-20-XX-2)

PLATING SPECIFICATION

- G: 20μ" GOLD IN CONTACT AREA, 3μ" ON TAIL
- T: MATTE TIN CONTACT AND TAIL
- S: 30μ" SELECTIVE GOLD IN CONTACT AREA, MATTE TIN ON TAIL
- L: 10μ" LIGHT SELECTIVE GOLD IN CONTACT AREA, MATTE TIN ON TAIL
- H: 30μ" HEAVY GOLD IN CONTACT AREA, 3μ" ON TAIL
- F: 3μ" FLASH SELECTIVE GOLD IN CONTACT AREA, MATTE TIN ON TAIL
- TM: MATTE TIN CONTACT AND TAIL
- SM: 30μ" SELECTIVE GOLD IN CONTACT AREA, MATTE TIN ON TAIL
- LM: 10μ" LIGHT SELECTIVE GOLD IN CONTACT AREA, MATTE TIN ON TAIL
- FM: 3μ" FLASH SELECTIVE GOLD IN CONTACT AREA, MATTE TIN ON TAIL

OPTION

- LC: LOCKING CLIP (-DV ONLY)  
(USE LC-09-TM)  
(SEE FIG 3, SHEET 2, SEE NOTE 14)
- A: ALIGNMENT PIN (-DV ONLY)  
(USE TMSH-XX-D-ES-XX-A)  
(SEE FIG 3, SHEET 2)
- \*-M: METAL PICK & PLACE PAD  
(-DV ONLY, USE LMP-04)  
(SEE FIG 4, SHEET 2)
- TR: TAPE & REEL  
(34 POSITION MAX, -DV ONLY)

ROW SPECIFICATION (SEE NOTE 12)

- D: DOUBLE THROUGH (SEE FIG 2)  
(USE TMSH-XX-D-ES)
- DV: DOUBLE VERTICAL (SEE FIG 1)  
(USE TMSH-XX-D-ES)

\* = FOR EXISTING CUSTOMERS ONLY

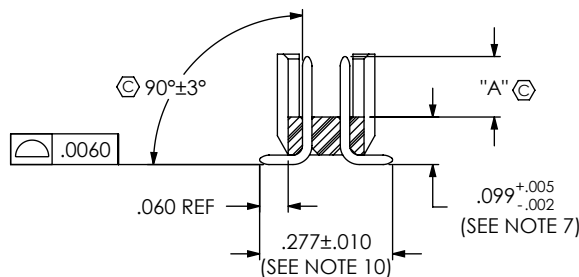

SECTION "A"- "A"

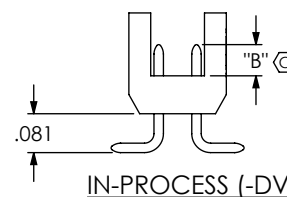

STYLE -05 IN-PROCESS (-DV)

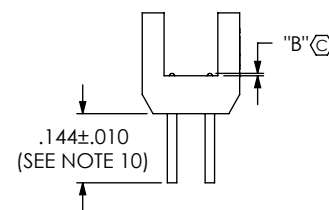

STYLE	"A"	"B"	TERMINAL	"L"
-01	.126	.065	T-1S13-07-XX-2	.302
-04	.075	.010	T-1S13-04-XX-2	.255
-05	.065	.005	T-1S13-20-XX-2	.323

UNLESS OTHERWISE SPECIFIED, DIMENSIONS ARE IN INCHES. TOLERANCES ARE:  
DECIMALS ANGLES  
.XX: ±.01 2°  
.XXX: ±.005  
.XXXX: ±.0020

PROPRIETARY NOTE

THIS DOCUMENT CONTAINS INFORMATION CONFIDENTIAL AND PROPRIETARY TO SAMTEC, INC. AND SHALL NOT BE REPRODUCED OR TRANSFERRED TO OTHER DOCUMENTS OR DISCLOSED TO OTHERS OR USED FOR ANY PURPOSE OTHER THAN THAT WHICH IT WAS OBTAINED WITHOUT THE EXPRESSED WRITTEN CONSENT OF SAMTEC, INC.

MATERIAL: DO NOT SCALE DRAWING  
INSULATOR: LCP, UL 94 V0  
COLOR: BLACK  
TERMINAL: PHOS BRONZE, ALLOY No 510

SHEET SCALE: 2.5:1

DESCRIPTION: 2mm END SHROUD TERMINAL ASSEMBLY

DWG. NO. TSH-1XX-XX-XX-DX-XX

BY: DEAN P 07-02-2010 SHEET 1 OF 2



520 PARK EAST BLVD, NEW ALBANY, IN 47150  
PHONE: 812-944-6733 FAX: 812-948-5047  
e-Mail: info@SAMTEC.com code 53322

FIG 3  
-LC & -A OPTIONS (-DV ONLY)

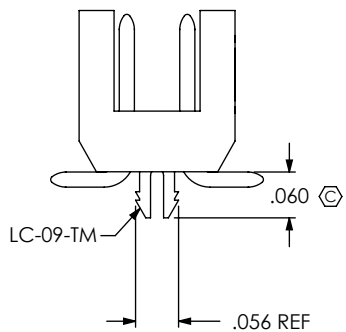

-LC OPTION

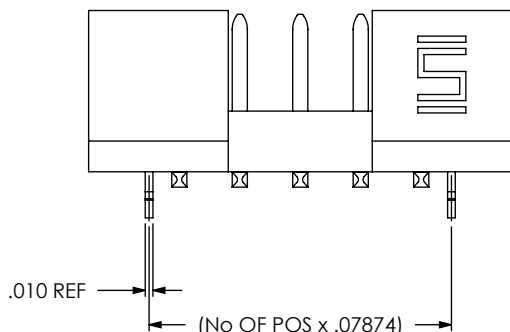

-A OPTION

PACKAGING VIEW

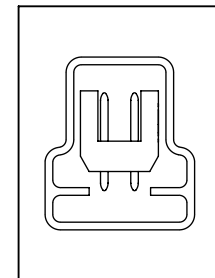

TSH-1XX-XX-XX-D-XX

TUBE: PT-1-24-04-15  
PLUG: TP-09

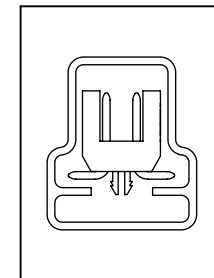

TSH-1XX-XX-XX-DV-XX

TUBE: PT-1-24-04-15  
PLUG: TP-09

IN-PROCESS BANDOLIER REF VIEW  
-T PLATING ONLY

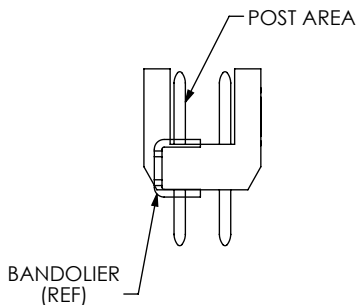

(SEE NOTE 13) Ⓢ  
(SEE TABLE 2)

FIG 4  
-M: PICK & PLACE PAD OPTION (-DV ONLY)

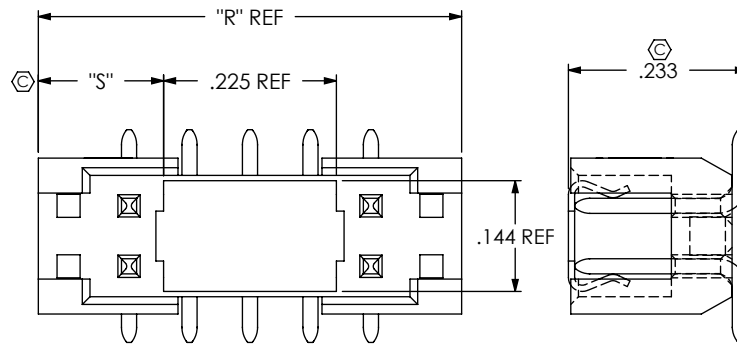

"R" = (No OF POS + 2) x .07874  
"S" = {("R" - .239) / 2} ± .020

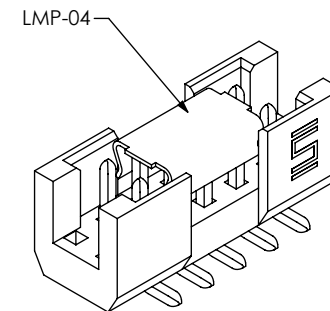

F:\DWG\MISC\MKTG\TSH-1XX-XX-XX-DX-XX-MKT.SLDRW

TABLE 2 (-T PLATING ONLY)

LEAD STYLE	NUMBER OF BAND MARKS ALLOWED IN THE POST AREA	
	PIN A	PIN B
*-01	0	0
*-04	0	0
*-05	0	0

\* PINS TO BE FLIPPED OPPOSITE OF SELECTIVE PLATING BEFORE BEING INSERTED

PROPRIETARY NOTE

THIS DOCUMENT CONTAINS INFORMATION CONFIDENTIAL AND PROPRIETARY TO SAMTEC, INC. AND SHALL NOT BE REPRODUCED OR TRANSFERRED TO OTHER DOCUMENTS OR DISCLOSED TO OTHERS OR USED FOR ANY PURPOSE OTHER THAN THAT WHICH IT WAS OBTAINED WITHOUT THE EXPRESSED WRITTEN CONSENT OF SAMTEC, INC.

DO NOT SCALE DRAWING

SHEET SCALE: 1:0.25



520 PARK EAST BLVD, NEW ALBANY, IN 47150  
PHONE: 812-944-6733 FAX: 812-948-5047  
e-Mail info@SAMTEC.com code 53322

DESCRIPTION:  
2mm END SHROUD TERMINAL ASSEMBLY

DWG. NO. TSH-1XX-XX-XX-DX-XX

BY: DEAN P 07-02-2010 SHEET 2 OF 2