

LTC6803-3 Battery Monitor

HARDWARE/SOFTWARE USERS GUIDE

DESCRIPTION

Evaluation circuit DC1653A is a Battery Monitoring System to demonstrate the functional operation of the **LTC6803-3** integrated circuit. The design includes the ability to daisy-chain up to 10 devices with built-in board-to-board ribbon-cable interconnects and selectively apply resistive loading to any cell for purposes of “Passive Balancing.” Additionally, the board includes an available DC-DC boost conversion section to power the IC from an isolated external 5V supply.

LTC6803-3 KEY FEATURES

- Separate Cell 0 ADC input (bottom-cell connection).
- Conversion range down to -300mV per cell.
- Robust daisy chain SPI common-mode immunity.
- Packet Error Checking on command writes.
- 6X lower standby current than LTC6802.
- Power-down mode for “no battery drain”.
- Active pullup on discharge-control outputs (S pins).
- Extensive diagnostic commands.

DC1653A DEMO FEATURES

- Controllable discharging for Passive Balancing.
- Enhanced protection circuitry for IC and external discharge transistors during hot plugging of cells.
- Graphical User Interface (GUI) screen for demonstration of new features and program code development.
- Available 60V boost supply from isolated 5V external supply. Jumper configuration offers -5V offset for V_{-} to support negative cell readings.
- Footprint for LTC6655-3.3 calibration reference.

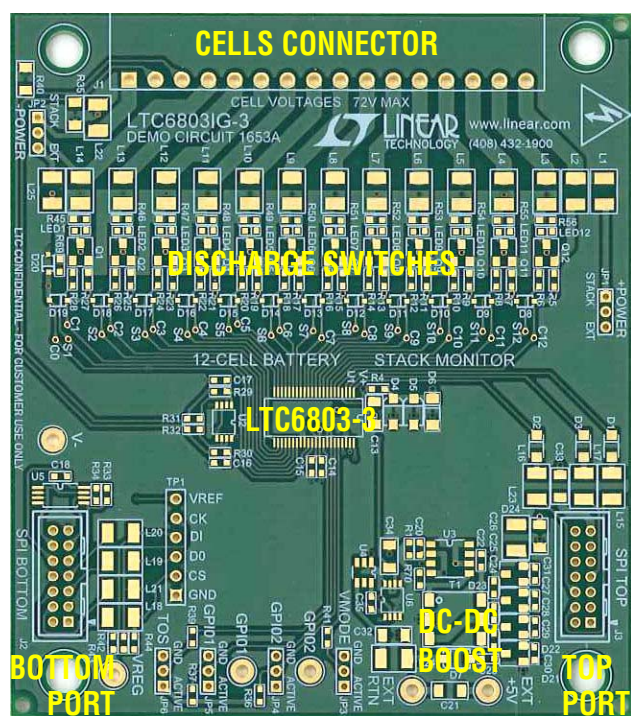

GETTING STARTED WITH ONE BOARD CONNECTED

SINGLE BOARD CONNECTION TO PC AND GUI

Step 1. Set jumpers on DC1653A to the default positions indicated in Table 1.

TABLE 1. JUMPER FUNCTIONS

JUMPER	FUNCTION	DEFAULT POSITION	DEFAULT POSITION	ALTERNATIVE POSITION
JP6	Top of Stack (TOS)	Active	Indicates that the cells monitored by the board are at the top of the battery stack. Data is not transferred in or out of the Top Port of this board.	Allows data to be passed to and from both the Top and Bottom Ports of the board.
JP5	General Purpose I/O (GPIO1)	Active	Output connected to pull-up resistor to Vreg. Can be programmed as an input or an output.	Forced to a logic low level.
JP4	General Purpose I/O (GPIO2)	Active	Output connected to pull-up resistor to Vreg. Can be programmed as an input or an output.	Forced to a logic low level.
JP3	Voltage Mode (VMODE)	Active	Bottom SPI port is configured as normal TTL voltage level inputs and outputs. Required setting for the board on the bottom of the battery cell stack. A 5KΩ PULL-UP RESISTOR MUST BE CONNECTED FROM THE SDO OUTPUT LINE (CONNECTOR J2, PIN 5) TO THE LOGIC POWER RAIL OF THE CIRCUIT DRIVING THE BOTTOM SPI PORT (SEE TEXT).	Bottom Port is configured as a current inputs and outputs. Required setting for all boards on a cell stack above the bottom board.
JP2	-POWER	Stack	Connects V- of the LTC6803 to the Cell 0 potential of the stack.	Forces V- to be at a potential 5V below Cell 0. Only usable if separate external power is applied. Permits all cells to properly measure down to -300mV.
JP1	+POWER	Stack	Connects V+ of the LTC6803 to the Cell 12 potential of the stack.	Connects V+ to the isolated boost power supply. Only usable if separate external power is applied. Permits full power-down of the LTC6803 when external power is removed.

Step 2. Connect DC590B Quick Eval USB cable to PC/Laptop USB port. Connect ribbon cable from DC590B to the Bottom Port of DC1653A (J2). Make sure that the driver for DC590B has been downloaded from www.linear.com and installed on the computer. This can be verified by running Quick Eval and seeing the message that there is a missing module for this board type. Close the Quick Eval program and then launch only the control program:

LTC6803-1-3_GUI_Vxx_yyyyymmdd.exe

When the DC590B Quick Eval board recognizes the String ID code from the DC1653A board, the program will open and present the control screen. This sometimes requires two launches of the GUI program to properly initialize.

A DC590B board has the required pull-up resistor to the SDO line already connected. **If a system other than DC590 is driving the bottom port (which must be set to Voltage Mode) must have a 5KΩ pull-up resistor added between the SDO line (J2, PIN 5) and the 3V/5V logic supply rail of the**

driving system. This pull-up resistor was not added to the DC1653 because it cannot be present when the port is configured for current mode operation on a multiple board monitor of a stack of cells.

Step 3. Connect the cells to be monitored to the cells connector J1. This connector is in two pieces. The setscrew piece can be unplugged to make it safer to attach wiring from a four to twelve cell battery stack. The LTC6803-3 is intended to measure from four to twelve individual cells with a total stack voltage of 10V to 50V.

With fewer than 12 cells to be monitored, the bottom cell of the stack should always be connected as Cell 1 between terminals J1-5(+cell contact) and J1-4(-cell contact). Terminal J1-4, is the Cell 0 reference point for the battery cell stack. The second cell on the stack connects between terminals J1-6(+cell contact) and J1-5(-cell contact). All higher numbered terminals on J1 not used for cell connections may be shorted together. If the V+ positive supply for the DC1653A is to be the cell stack, then the terminal J1-16 must connect to the top of the battery stack. Figure 1 illustrates a connection for fewer than 12 cells.

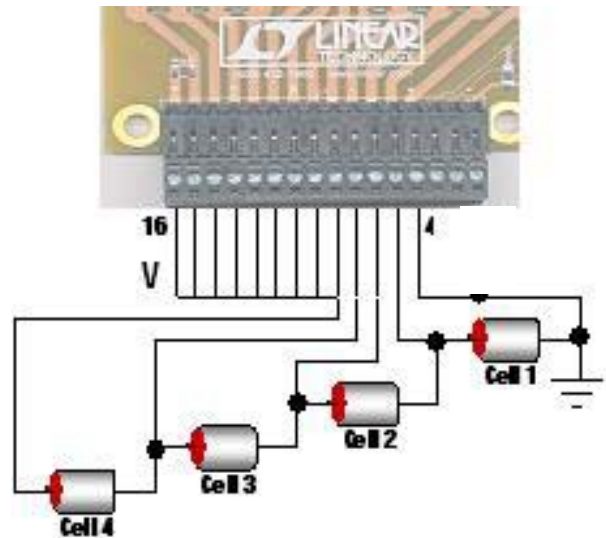

Figure 1. Connection of four cells (cell voltages at least 2.5V)

SPECIAL NOTE FOR DEMONSTRATION PURPOSES

DC1653A and the GUI program are useful to serve as a demonstration tool to highlight the features of the LTC6803-3. If actual battery cells are not available, a series string of 150Ω resistors connected between each of the J1 connector terminals can be used instead. Each resistor will serve as a cell voltage. A lab power supply voltage of 10V to 50V can be connected across the resistor string between terminals J1-16(+) and J1-4(-).

When using resistors instead of cells, the discharge indicating LEDs on the DC1653A board will not light due to limited available current in the resistor-string.

Step 4. Apply power.

Inserting the setscrew piece into connector J1 will apply power to the board from the battery cell stack. For the demo set up simply turn on the lab power supply preset to a voltage between 10V and 50V.

THE CONTROL PROGRAM

THE GRAPHICAL USER INTERFACE (GUI) SCREEN

Figure 2 shows the control panel that appears on the computer screen. The DC1653A board must be connected to the DC590 interface card for the program to open. The control screen will close if any of the boards are disconnected. Controls on this panel are used to communicate with the LTC6803-3. Commands are issued and information is retrieved and displayed on this screen. This panel is useful not only for demonstrating

the operation of the LTC6803-3, but also for software developers to observe the Hex codes exchanged with the device.

The control screen makes good use of color to provide cell status and operating conditions at a glance. White indicates non-existent or stale data. A step by step procedure for one board connected to a stack of cells follows to explain the operation of the control panel. Sections are highlighted for each procedure.

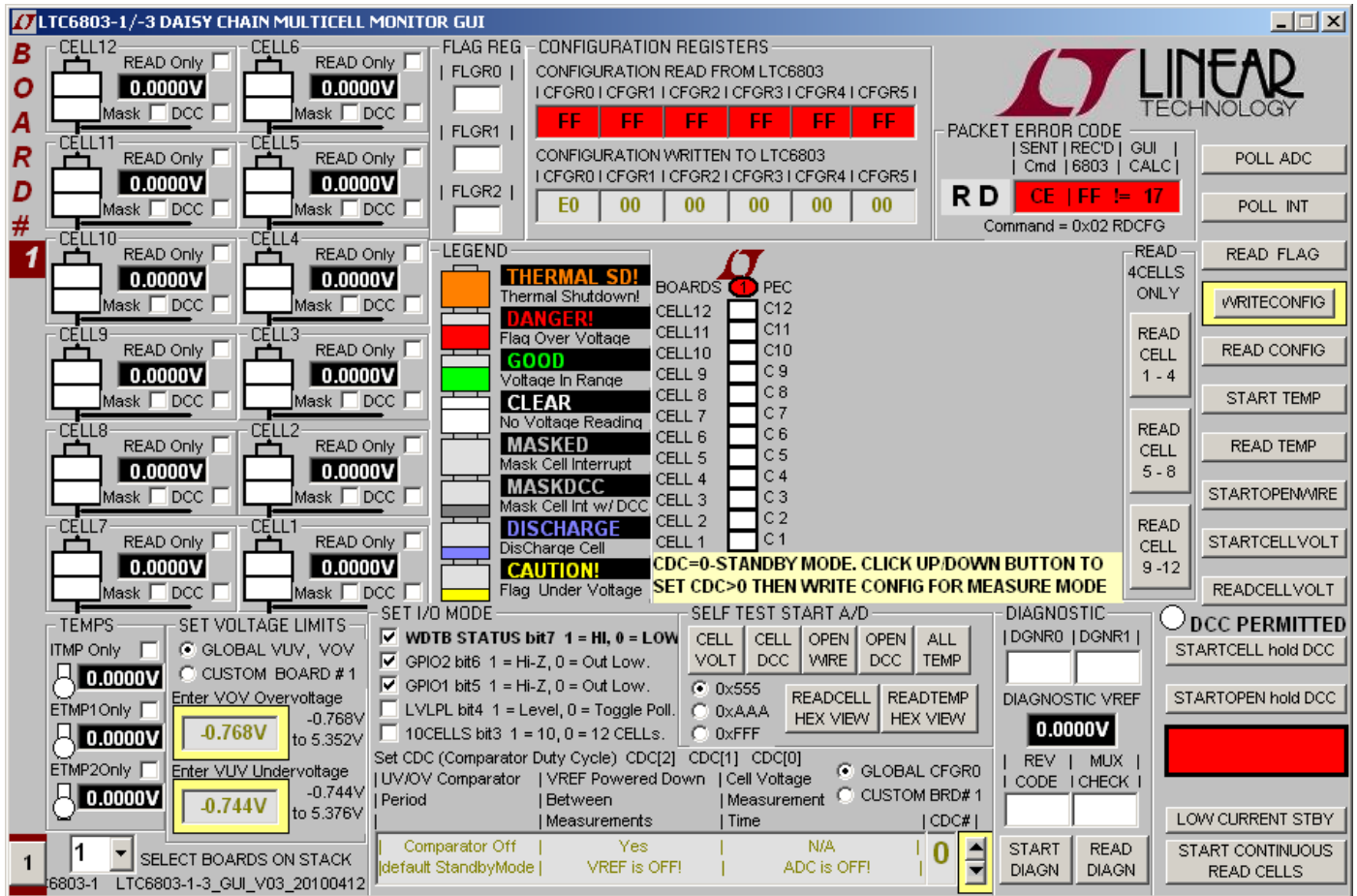

Figure 2. GUI Control Panel Start-up Screen

OPERATING THE CONTROL SCREEN

FIRST THINGS FIRST

Figure 2 is the initial start-up screen that appears when the program is launched and the Quick Eval interface card recognizes that the DC1653A board is connected. Once power is supplied to the board from a stack of cells or a power supply, the communication between the PC and the board can be checked.

1: READ CONFIGURATION

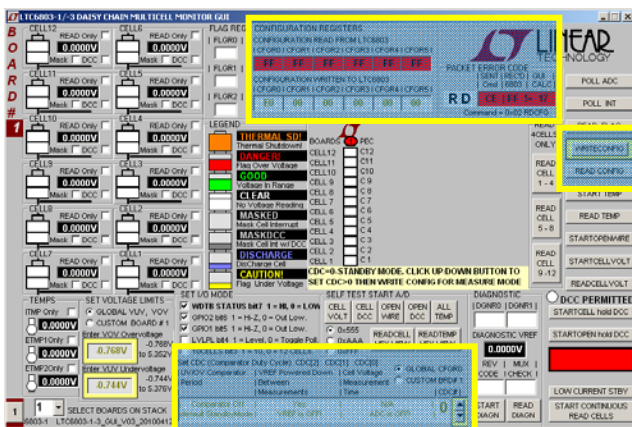

Click the command button labeled **READ CONFIG**. If all is properly connected and operating the start-up default configuration of the LTC6803-3 will be read from the board. The Hex codes for the six bytes of configuration setting will appear in the **CONFIGURATION REGISTERS** section in the boxes labeled **CONFIGURATION READ FROM LTC6803**. The initial configuration bytes should be 0xE0 for register 0 and 0x00 for the other five bytes. **This default configuration is the standby mode for the LTC6803. To enable the device and begin taking cell voltage measurements, a CDC (Comparator Duty Cycle) setting other than Standby must be selected from the SET I/O MODE set CDC selection box at the bottom of the GUI screen. Once chosen, a WRITE CONFIG command must be executed.**

In addition the LTC6803 calculates a Packet Error Code, PEC, and appends it to the data stream each time it sends out data. For the six bytes sent by this

command and received by the GUI, the control program calculates a PEC in the same manner. This byte is compared with the appended receive byte to check that the data transmission was properly executed. The Received PEC byte and the calculated PEC from the received data are displayed in the top section labeled **PACKET ERROR CODE** and both bytes should match. The oval located at the top of the color-coded status panel for the one board will turn green if the PEC bytes match. Data transmission errors will produce red warning indications if the PEC bytes do not match. There is also a display of the PEC that was sent with the most recent command to the LTC6803, which had to match an internally calculated value to be accepted as a valid command.

2: WRITE CONFIGURATION

Nothing is changed within the LTC6803 until the Write Configuration command is executed. Clicking the **WRITE CONFIG** command button does this. When the command is sent, the six Hex bytes shown in the **CONFIGURATION REGISTERS** section in the boxes labeled **CONFIGURATION WRITTEN TO LTC6803** will become **bold** type. Software developers can note the exact hex values required by the LTC6803 for specific conditions in these boxes to facilitate their control program development.

Clicking the **READ CONFIG** button can see confirmation that the configuration change was actually made. The six bytes read back should match the six bytes sent and the PEC/CRC check bytes should be a match (green PEC oval on stack display).

When any configuration information is changed on the screen the **WRITE CONFIG** command button will be back-lit illuminated. This serves as a reminder that this command still needs to be executed.

IMPORTANT NOTE

No configuration changes take effect until the WRITE CONFIG button is clicked. The GUI provides a periodic background command so that watchdog does not trigger a CDC reset back to 0.

3: PROGRAM THE CELL MONITORING VOLTAGE THRESHOLDS

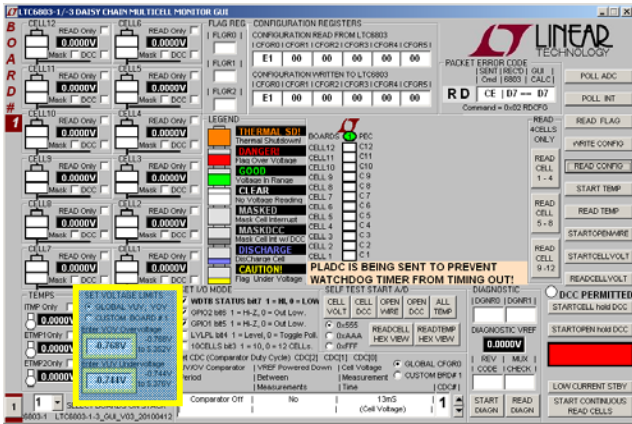

In the section labeled **SET VOLTAGE LIMITS** click on the boxes and enter voltage values for the over-voltage and under-voltage thresholds required for the cells being monitored. The voltage value entered will be rounded to the actual value used by the LTC6803 and displayed in the box. The voltage ranges for these thresholds is -0.74V to 5.35V and the program will not allow the under-voltage to be greater than the over-voltage threshold.

These monitor thresholds can be applied globally to each and every cell in the system or customized for the cells connected to an individual board by clicking the desired option button. Individual boards are selected for programming by the left hand tabs in multiple board systems.

4: READ CELL VOLTAGES

The essential function of the LTC6803 is to measure and report the voltage on each battery cell when commanded. Once again this is accomplished from the control screen with two command button clicks. First click on the **START CELL VOLTAGE** button. This commands an A/D conversion of all 12-cell voltages in the time configured from the selected Set CDC option in the **SET I/O MODE** box. The actual cell voltage measurements are not displayed until the **READ CELL VOLTAGE** command button is clicked.

5: READ FLAGS

When any cell in a stack exceeds the programmed over or under voltage threshold limit, one of two flag bits is set in an internal register for that cell to serve as a warning. This is important feedback for battery charging algorithms to know when to start or stop charging. To read the state of these warning flags at any time is a simple click of the **READ FLAG** command button. The Hex code for the three flag bytes appears in the **FLAG REGISTERS** section of the control panel.

One of the configuration options is to mask these flags from appearing in the register bytes that are read from the LTC6803. This feature can be used to prevent or allow these flags to affect a control algorithm. A check box is provided for each cell in a stack to select the mask interrupt option for that cell. To implement the masking requires checking the box and then writing the new configuration with a **WRITE CONFIG** button push.

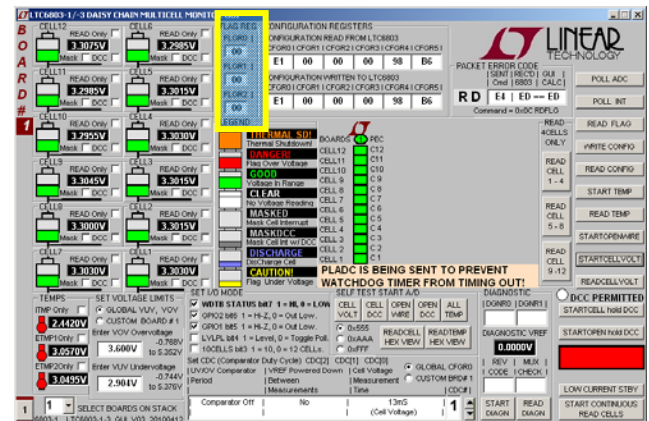

If the measured voltage of a cell is within the monitoring thresholds all indications for the cell appear green.

5: READ TEMPERATURE

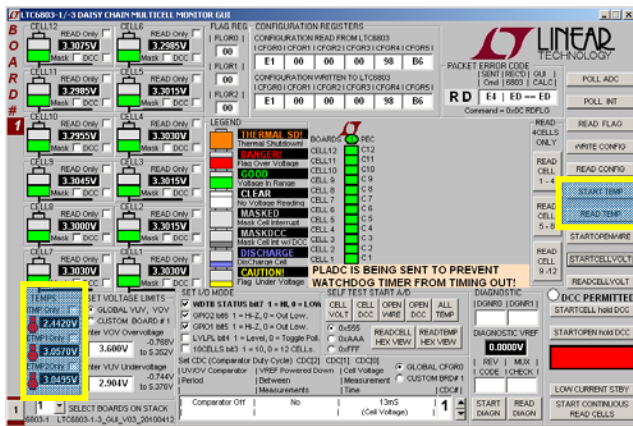

The LTC6803 has three ADC channels dedicated to measuring temperature. The temperature indications are for the internal die temperature of the LTC6803 and two externally connected thermistors. The display returns a voltage measurement.

The internal die temperature sensor produces a voltage that changes at a rate of 8mV/°C relative to absolute zero. To convert the voltage reading to degrees Celsius, divide the voltage by 8mV then subtract 273°C. For example, 25°C is a reading of 2.384V.

For external temperature measurements connect thermistors across cells connector terminals J1-3 to J1-1 and J1-2 to J1-1. A thermistor with a 25°C value of 10KΩ will produce a voltage reading of ~VREF/2 at 25°C. Other thermistor values may be used but scaling the voltage measurement may require changing the values of resistors R31 and R32 on the DC1653A circuit board.

To take a temperature reading simple click the **START TEMP** command button to make the LTC6803 ADC conversion followed by clicking the **READ TEMP** command button to download the data from the board and display the voltage readings.

6: READ AN INDIVIDUAL CELL OR TEMPERATURE

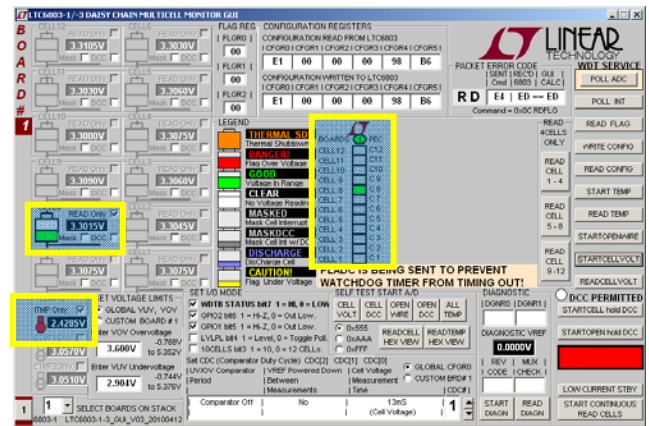

Each cell and each temperature channel has a check box to allow individual measurements. Checking these “Only” boxes sends the command (**STARTCELL VOLT** then **READCELL VOLT**, **START TEMP** then **READ TEMP**) to read only that channel and display its status. Cell 8 and Internal Temp are shown in the example screen above. Older or stale readings for all other cells and temperatures are faded out.

8: DISCHARGE CELLS

Another major feature of the LTC6803 is the ability to remove charge from individual cells. This can help to distribute the cell charge evenly over a stack of batteries. DC1653A contains a P channel Mosfet in series with a 33Ω resistor across each cell connection. When enabled, a cell is loaded and charge is pulled from the cell with energy dissipated in the switch and resistor.

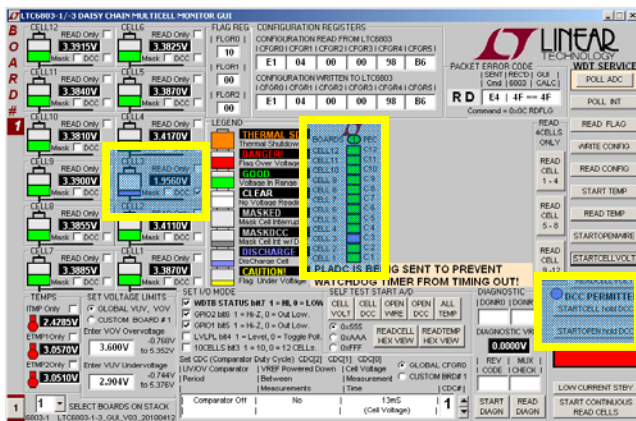

A check box is provided for each cell to be discharged. Checking this box (Cell 3 in the above example screen shot) and then writing the new configuration with a **WRITE CONFIG** button push will load the cell.

IMPORTANT NOTE: The discharge transistors are automatically turned off momentarily while the A/D converter is measuring the cell voltage using the normal **STARTCELL VOLT** command. This prevents any voltage drop errors caused by the discharge current flowing through the cell inter-connection wiring. An accurate indication of the true state of charge of the cells is then obtained.

The LTC6803 offers the option of keeping the discharge transistors on while measuring the cell voltages. This is done using the **STARTCELL hold DCC** command. A blue indicator is illuminated when this command has been executed. This lower voltage reading also includes I*R errors introduced by cabling and connectors.

OTHER CONTROL FEATURES

Three additional command buttons are provided on the control screen. The **POLL ADC** and **POLL INTERRUPT** command buttons are used to test if the ADC is busy making conversion and to test if any of the LTC6803 devices in a system have an interrupt condition respectively. The result of these commands can be observed by monitoring the serial data output line of the SPI interface to the Bottom Port, J2. There is no indication provided on the control screen.

The **START OPENWIRE** command button connects the built in open wire detection circuitry to all cells. This command must be followed by **READCELL VOLT** command button click to see the result. An open wire connection to any cell will be indicated by an abnormally high voltage measurement for the cell above the open wire and a near 0V measurement for the cell with the open wire.

CONTINUOUS OPERATION

For convenience, the control panel allows for continuous operation of the DC1653A board. The command button labeled **START CONTINUOUS READ CELLS** can be clicked and the board control is placed in a continuous loop executing the following commands automatically in the following sequence:

- Start cell voltage
- Read cell voltage
- Start temp
- Read temp
- Read flags

All values are updated continually (~800ms update rate). While running, the configuration can be changed on the fly. Simply changing a configuration item (Discharge cells for example) and clicking the **WRITE CONFIG** button will implement the new configuration and return to continuous operation.

A green box in the lower right hand corner indicates that the system is running continuously. A red box means that the system is stopped and waiting for a new command to be sent.

DISPLAYING VALID DATA TRANSFERS ONLY

Each time data is transferred from the LTC6803 by the four READ commands (Cell Voltage, Configuration, Flag Status and Temperature), a Packet Error Code, PEC, is appended based on the data stream sent. The control program also calculates a PEC value based on the data it receives. If the calculated PEC matches the transmitted value the data transfer is assumed to be error free and therefore the data is valid.

If the two PEC values do not match, the transmitted data stream has been somehow corrupted. This type of data error becomes more of a concern when boards are stacked and the transmit data stream is lengthened. The transmitted and calculated PEC values are displayed on the GUI and turn red when a mismatch occurs.

LOW CURRENT STANDBY

An important system consideration is the ability to put the monitoring circuitry into a low current drain condition. This is done by setting the LTC6803 into its standby configuration. A command button in the lower right corner of the screen is provided to facilitate this function. Once pushed all data and configuration settings are reset and the screen goes white on all indicators.

SELF TEST & DIAGNOSTIC FUNCTIONS

The LTC6803 has built in self test and diagnostic functions. These commands apply a test signal to the ADC to check that the internal cell voltage and temperature connections are functioning. The cell voltage and open wire test signals can be applied with or without the discharge transistors active. Checking the functionality of each bit in the internal data registers for cell voltages and temperatures can also be seen by choosing which test code (0x555, 0xAAA, or 0xFFFF) to expect to be returned from the device when a self test command is issued.

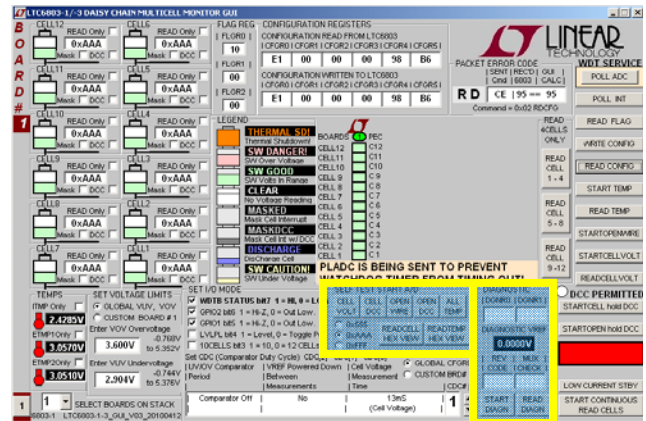

OTHER CONFIGURATION OPTIONS

The SET I/O MODE group of checkboxes can be used to adjust other features of the LTC6803. Configuring the general purpose I/O pins and setting the type of activity polling scheme can be selected then configured with a WRITE CONFIG button push.

EXTERNAL POWERING OPTION

The DC1653A includes circuitry that can power the LTC6803 separately from the monitored cells. A low-power isolated DC-DC conversion function accepts a 5.0V input and provides about 60V between V+ and V-. To enable this mode, the +POWER jumper JP1 must be set to the EXTERNAL setting. This disconnects V+ from the battery stack and allows the LTC6803 to completely power-down with removal of the external energy source, dropping battery drain to mere nA leakage levels for best long-term storage conditions. The external 5V supply will have to provide about 50mA in normal operation.

When using the external power option, there is also a choice of configuration for the biasing point of V-. The -POWER jumper JP2 will tie the bottom cell potential (cell 0) to either V- (the STACK position) or to 5V above V- (the EXTERNAL position). The latter provides the needed common-mode headroom the ADC requires to support negative cell-voltage readings by forcing V- to be 5V below cell 0.

EXTERNAL CALIBRATION OPTION

The DC1653A provides a solder-pad footprint to accept the LTC6655 high-accuracy reference. The reference is powered from the external DC-DC function through the local 5V regulator provided (which also creates the biasing for the –POWER EXT option). The reference voltage is digitized by the VTEMP1 ADC channel (instead of a thermistor signal) and may be used to provide corrective information on the battery readings. A 3.300V or 4.096V model is recommended. The reference is enabled by setting GPIO1 to “0” using a configuration command, or placing the GPIO1 jumper JP5 to the GND position.

STACKING BOARDS TO ADD MORE BATTERY CELLS

A unique characteristic of the LTC6803-3 is the ability to communicate serial data up and down a stack of devices connected to any number of battery cell stacks. Likewise any number of DC1653A boards, monitoring up to 12 cells each, can be stacked in daisy chain fashion. The control GUI however is limited to only 10 boards (120 cells maximum). To stack and control more than one board requires the following hardware and software modifications:

MULTI-BOARD HARDWARE ADJUSTMENTS

1. The bottom board on the stack, which connects to a system controller or to a DC590 Quick Eval link to a PC, must have its Bottom Port set to voltage mode. Jumper JP3 (VMOD) must be connected to the ACTIVE position. **If not using DC590, a 5K Ω pull-up resistor must be connected from the SDO output line (connector J2, pin 5) to the 3V/5V logic power rail of the circuit driving the bottom SPI port.**
2. Every board connected above the bottom board must have its serial ports set to Current Mode. Connect VMODE Jumper JP3 to the GND position on each board to set this.
3. The final board on the top of the stack must have JP6 (TOS) set to ACTIVE. Connect JP6 (TOS) on all other boards to the GND position.

4. A ribbon cable must connect the Top Port (J3) of a lower board to the Bottom Port (J2) of the next board up on the stack. The daisy chain linking with ribbon cables from the Top port of a lower board on the stack to the Bottom port of the next board above it establishes the serial data link for the entire stack.

CAUTION! CAUTION! CAUTION!

As battery cells are stacked on top of each other, great care must be taken to prevent damage and personal injury from the very high voltage potentials that may be present. Do not allow short circuit connections, whether electrical or human, between a high voltage point and the system or chassis ground at the bottom of the stack. Be very careful and respect the potential danger of high voltage!

IMPORTANT NOTE FOR DEMONSTRATION OR EVALUATION WHEN NOT USING BATTERY CELLS IN A STACK

When using DC1653A boards in a stacked application where a resistor string is used to simulate cell voltages an extra wire must be added to connect the V+ potential of a lower board to the V- potential of the next board up on the stack. Connector J1, pin 16 of a the lower board must be connected to the connector J1, pin 4 of the next board above it on the stack. The wire making this connection should be kept as short as possible (less than 2 inches or 5 cm). **This supply connection is not provided by the ribbon connector and is required to enable data communication up and down the stack.**

SOFTWARE ADJUSTMENTS

The GUI program can control up to ten boards on a stack.

1. Select the number of boards on the stack from the pop up window located near the command buttons at the bottom of the screen.
2. Select whether the Operating Configuration (CDC Comparator) and Over/Under voltage thresholds for each board are to be the same (GLOBAL) or different for each board (CUSTOM) and set the duty cycle and voltages accordingly.
3. A tab will appear on the left edge of the control panel for each board on the stack. Clicking on any of these tabs will transfer control commands and data to and from the display screen to that selected board.

COLOR CODED STATUS PANEL

The color-coded status panel will expand to include all boards connected in a stack. Each small square in this array represents an individual battery in the stack of boards. The intent of this display is to provide a way to see the status of all cells at a glance. The significance of the colors used is explained in the legend on the screen.

Any grayed box indicates that the cell's interrupt flag has been masked so the LTC6803 is no longer reporting this status. The cell voltage value measured for this cell however is still accurate.

The next page shows the schematic for DC1653A. Consult the data sheet for detailed information concerning the operation of the LTC6803-3.

