

LOC	DIST	REVISIONS			
P	LTR	DESCRIPTION	DATE	DWN	APVD
AF	50	1	PROPOSED	-	-

- 1 CONTINUOUS STRIP ON REELS WITH TERMINALS LOCATED ON 6.86±0.08 [.270±.003] CENTERS
- 2 SLOT ACCEPTS 0.36-0.51mm [#27-#24] AWG COPPER MAGNET WIRE. TWO WIRES OF THE SAME SIZE MAX PER SLOT.
- 3 IDENTIFICATION NUMBER 10 FOR THE MAGNET WIRE SLOT SIZE.
- 4 0.25 [.010] MAX CARRIER CUT-OFF
- 5 PRELIMINARY - NOT FOR PRODUCTION

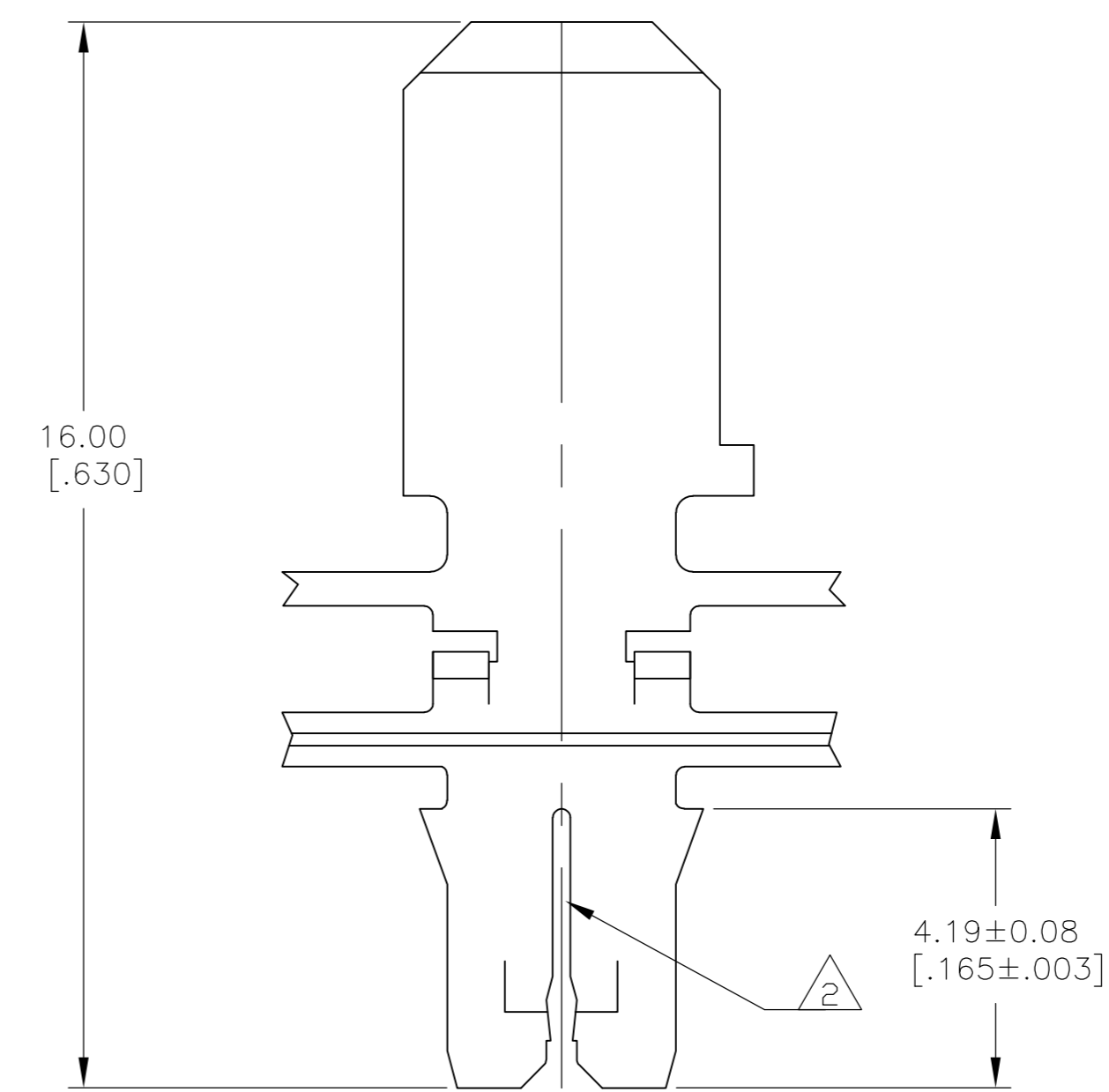
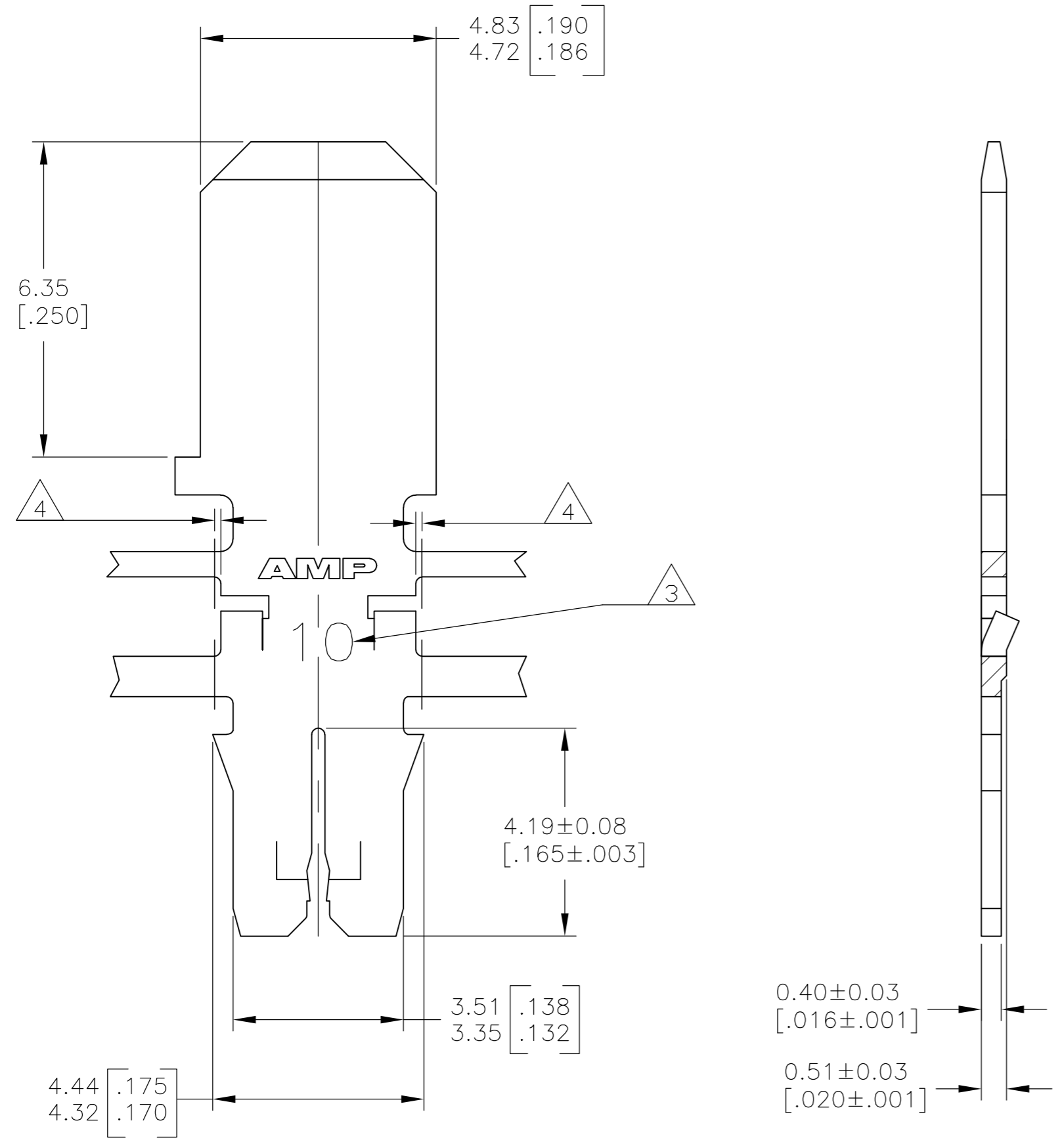

0.002032 [.000080] MIN TIN PLATE	082 PRE-MILLED BRASS	5 1742859-1
FINISH	MATERIAL	PART NO.

THIS DRAWING IS A CONTROLLED DOCUMENT.		DWN	JR RUTH	27OCT10	Tyco Electronics Corporation Harrisburg, PA 17105-3608
DIMENSIONS: MM [INCHES]		CHK	KURT RANDOLPH	27OCT10	
TOLERANCES UNLESS OTHERWISE SPECIFIED:		APVD	KURT RANDOLPH	27OCT10	
0 PLC ± - 1 PLC ± - 2 PLC ± 0.13 [.005] 3 PLC ± - 4 PLC ± - ANGLES ± -		PRODUCT SPEC	108-1484	NAME	
MATERIAL	SEE TABLE	FINISH	SEE TABLE	APPLICATION SPEC	114-2140
CUSTOMER DRAWING		WEIGHT	-	SIZE	A2
		CAGE CODE		00779	DRAWING NO
		SCALE		10:1	RESTRICTED TO
		SHEET		1 of 1	REV
					1

1742859