

PART NUMBER	REV	FIRST USED
567940-1	C	854040-3

TERMINAL NAME: TAB					
VISIBLE PAD LTR	CRIMP HEIGHT	WIRE SIZE			
A	.039 ±.002 [0.99 ±0.05mm]	20			
B	NOT	USED			
C	NOT	USED			
D	NOT	USED			
CRIMP	SIZE	TYPE	RANGE		
WIRE	.062 [1.57mm]	F	20		
INSUL	.090 [2.29mm]	F	-		
WIRE STRIP LENGTH	TERM APPL SPEC	FEED	APPL INSTRUCTION	SET UP GAGE	LAYOUT
.172-.203	NONE	.395	SEE CUSTOMER MANUAL	NONE	L1975

SIM TO HDM NONE

QTY	REV	U/M	DWG SIZE	PART NO	DESCRIPTION	ITEM NO
2	-	C		4-354779-4	PIN, WIRE DISC (.3210)C	129
						128
						127
						126
1	-	A		986950-1	WASHER, FLAT PRECISION	125
1	-	A		217238-3	GENERAL INSTRUCTION PACKAGE	124
						123
						122
1	-	A		4-21028-0	PIN,SLT SPR(φ.093x.75)ST GDE PL	121
1	-	B		690701-2	PLATE, SERIAL NO.	120
2	-	A		21899-2	WASHER,FLAT(#10)S G ADJ BLK	119
						118
2	-	A		21024-5	WASHER, LOCK(#10)ADJ BLOCK	117
						116
						115
2	-	A		21024-2	WASHER,LOCK(#4)FRONT STP GUIDE	114
REF	-	A		21024-4	WASHER,LOCK(#8)FEED FINGER	113
2	-	A		21024-4	WASHER,LOCK(#8)DEP-HOLD	112
REF	-	A		21024-4	WASHER,LOCK(#8)STRIPPER	111
						110
						109
1	-	A		21018-5	NUT,HEX(#6)HOLD DOWN	108
						107
						106
						105
1	-	A		21009-2	SCR,SKT SET(1/4-20x.25 LW)RAM	104
						103
						102
4	-	A		21017-2	SCR,DRIVE(#2x.19)ID PLATE	101
1	-	B		819347-1	PLATE, IDENTIFICATION	100
2	-	A		3-21002-0	SCR,BHC(10-32x.88)DRAG	99
1	-	A		22733-8	SCR,BHC(8-32x.38 LW)ANVIL	98
						97
1	-	A		3-21000-8	SCR,SHC(10-32x.88)MOUNTING	96
1	-	A		2-21002-7	SCR,BHC(10-32x.50)56 ADJ BLK	95
6	-	A		2-21002-2	SCR,BHC(8-32x.50)SHEAR-TERM SUP	94
						93
						92
1	-	A		1-21002-7	SCR,SHC(6-32x.50)CAM	91
4	-	A		2-21000-7	SCR,SHC(8-32x.50)SCR BLK	90
						89
						88
						87
REF	-	A		2-22603-0	SCR,HEX HD(8-32x.31)FEED FINGER	86
2	-	A		1-21000-3	SCR,SHC(4-40x.25)F ST GUIDE	85
REF	-	A		22733-9	SCR,BHC(8-32x.50 SL)STRIPPER	84
						83
						82
1	-	A		3-22603-1	SCR,HEX(10-32x.38)56 ADJ BL	81
						80
						79
						78
2	-	B		463310-5	BLADE, STRIPPING (#20)	77
						76
						75
1	-	A		690603-1	SPRING, ASSIST	74
1	-	A		23030-1	SCR,SKT CAP(6-32x.25)CP DSC	73
						72
						71

QTY	REV	U/M	DWG SIZE	PART NO	DESCRIPTION	ITEM NO
-1	U/M					

QTY RECD PER ASSY				PARTS LIST			

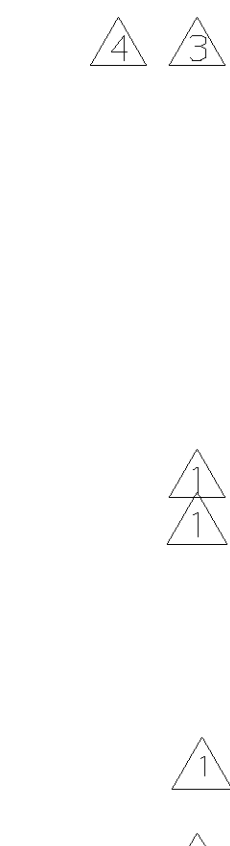

THIS DRAWING IS A CONTROLLED DOCUMENT.

THIS DRAWING IS UNRELEASED. RELEASED FOR PUBLICATION BY AMP INCORPORATED. ALL RIGHTS RESERVED. AMP 1756 REV 3-92

LOC A DTST 66

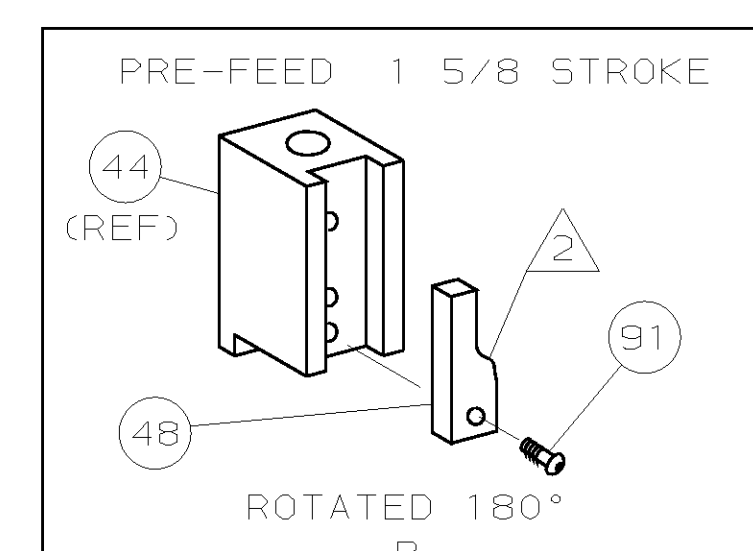

- 1 RECOMMENDED SPARE PARTS.
- 2 GREASE LIGHTLY.
- 3 ITEM NOT SHOWN
- 4 ITEM 18 IS TO BE INSTALLED TO CLEAR THE FLOATING SHEAR HOLDER ITEM 10.

5. ON THE STRIPPER CRIMPER MACHINE, POSITION THE FRONT METAL GUARD ON THE FRONT SIDE OF THE LEXAN DOOR

QTY RECD PER ASSY				PARTS LIST			

DIMENSIONS IN INCHES. DO NOT SCALE PRINT. TOLERANCES UNLESS OTHERWISE SPECIFIED:		MATL	HT TR	FIN
2 PLC DEC ±	3 PLC DEC ±	DR B.HIGMAN	APP T.ELBIN	
4 PLC DEC ±	ANGLES ±	CHK OSMAY98	REL -	
SURF TEXTURE: <input checked="" type="checkbox"/>	REMOVE BURRS, BREAK SHARP EDGES R.015 MAX	C.ERISMAN		
NAME STRIPPER CRIMPER APPLICATOR		MACHINE REF STRIPPER CRIMPER		
SCALE -	DWG NO 567940	SHEET 1 OF 1		REV C1

CUSTOMER AND ASSEMBLY DRAWING

567940