

NOTES:

1. MATERIALS AND FINISHES:
 BODY, OUTER CONTACT & COUPLING NUT - BRASS, SILVER PLATING
 CONTACT - BRASS, GOLD PLATING
 INSULATOR - PTFE, NATURAL
 RETAINING RING - PHOSPHOR BRONZE, NICKEL PLATING
 GASKET - SILICONE RUBBER, RED
 FERRULE - COPPER, SILVER PLATING
2. ELECTRICAL:
 A. IMPEDANCE: 50 OHM
3. MECHANICAL:
 A. DURABILITY: 500 CYCLES MIN.
 B. TEMPERATURE RANGE: -65° C TO +165° C
4. PACKAGING:
 A. QUANTITY: SINGLE PACK
 B. MARKING: BAG TO BE MARKED
 "AMPHENOL RF, 82-4425, AND DATE CODE"
5. CABLE ASSEMBLY INSTRUCTIONS
 A. TRIM CABLE AS SHOWN.
 B. INSERT CABLE CENTER CONDUCTOR TO CONTACT. SOLDER OR CRIMP CONTACT WITH 0.100" HEX
 C. INSERT CABLE INTO CONNECTOR WITH BRAID OVER KNURL UNTIL IT BOTTOMS.
 D. CRIMP FERRULE WITH 0.429" HEX
6. HEAT SHRINK TUBING (68180-4) SUPPLIED ON REQUEST ONLY.
7. SHOWS CABLE ENTRY DIMENSIONS.
8. CUSTOMER NOTE: SOLDER CONTACT TO CABLE

THIRD ANGLE PROJ.

REVISIONS

REV	DESCRIPTION	DATE	ECO	APPR
--	RELEASE TO MFG.	--	--	--
T	REDRAWN IN PRO-E & COD ADDED	11/18/13	49751	KR

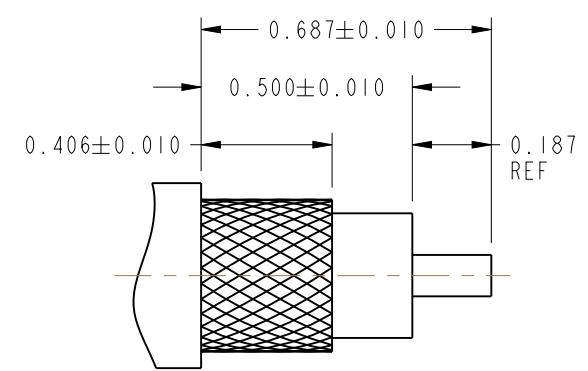
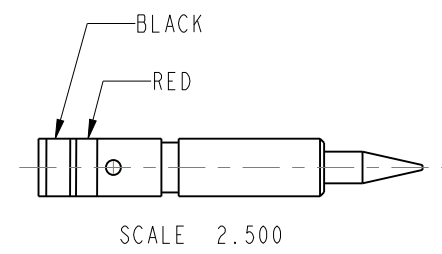

RECOMMENDED CABLE STRIPPING DIMENSIONS

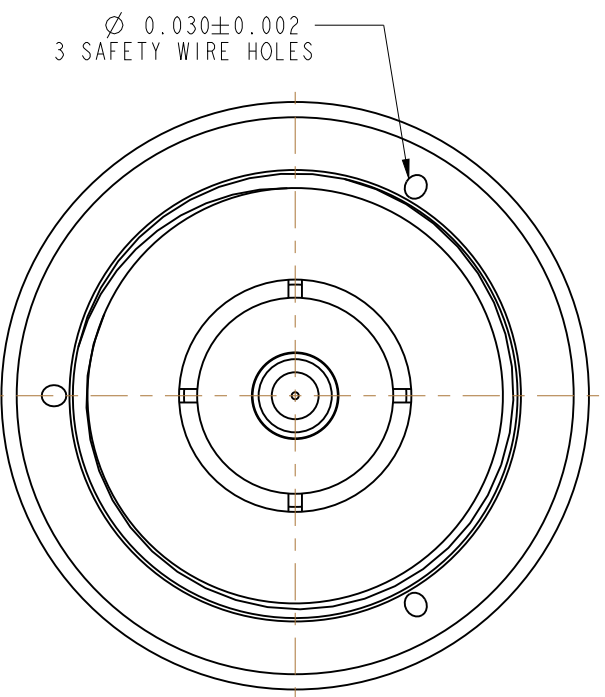
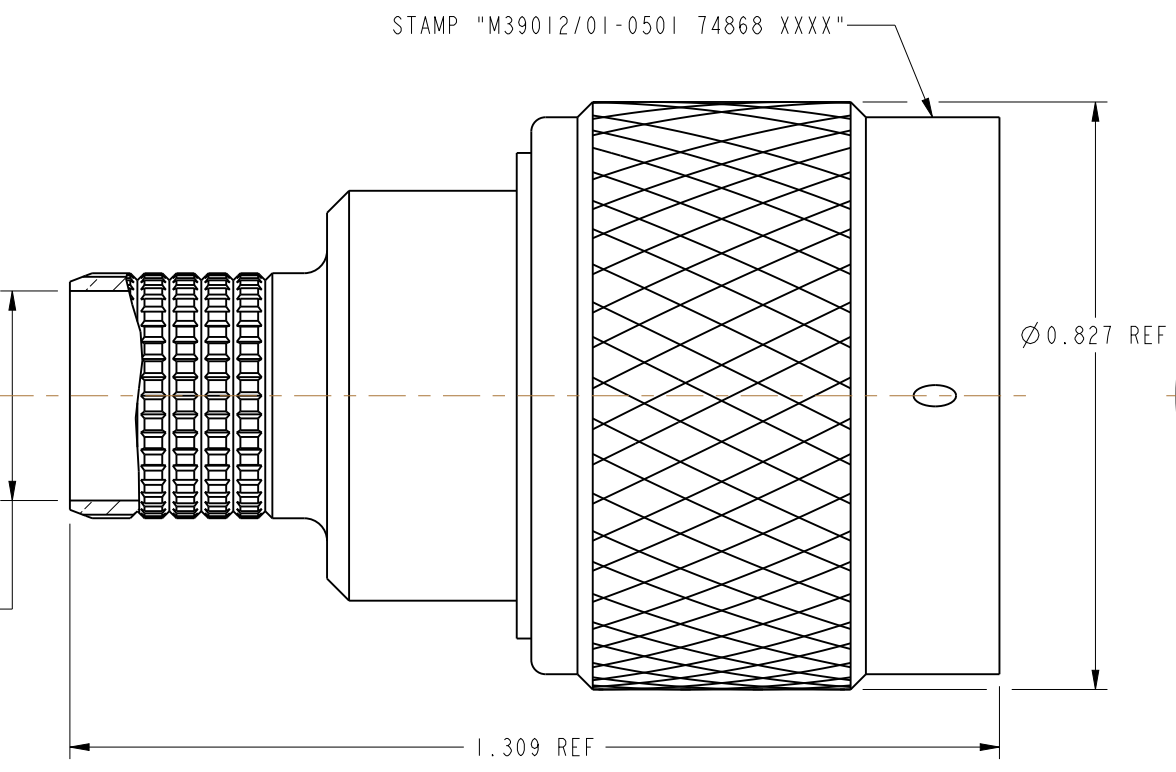
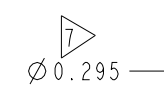
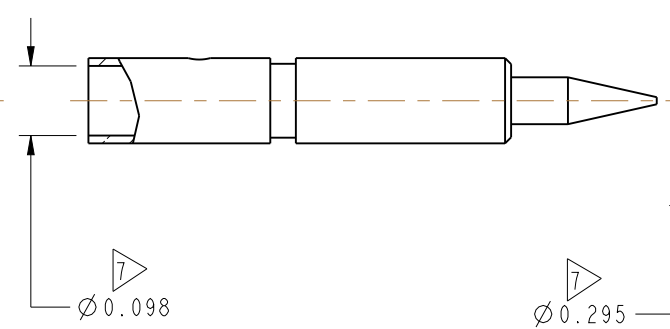
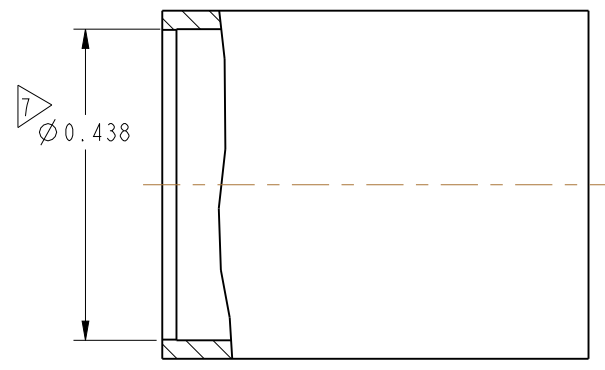
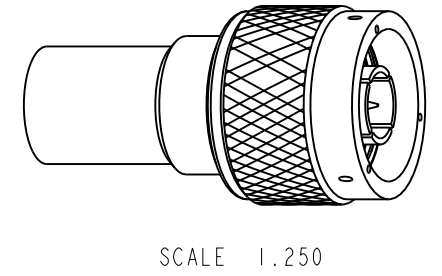

THIS CONNECTOR IS COVERED BY U.S. PATENT 3,439,294 & 3,474,391

MIL-C-39012 INSPECTION

CUSTOMER OUTLINE DRAWING

ALL OTHER SHEETS ARE FOR INTERNAL USE ONLY

UNLESS OTHERWISE SPECIFIED, DIMENSIONS ARE IN INCHES AND TOLERANCES ARE: 2 PLACE DECIMAL 3 PLACE DECIMAL ANGLES ±.015 (0,381 mm) ±.005 (0,127 mm) ± 1°	MATERIAL	DRAWN	DATE	TITLE TYPE 'N' PLUG MIL-CRIMP (CATEGORY D) FOR RG9,214,225 & 393/U CABLES		Amphenol RF www.amphenolrf.com DRAWING NO.82-4425 ITEM NO.82-4425 PART NO.82-4425
	SEE NOTES	KARTHIK R	03-Oct-13			
	REFERENCE	ENGINEER	DATE	SCALE: 3.7:1.0 SHEET 2 OF 2		
	DOR 309448-51 MIL-C-39012/01-0501	O. BARTHELMES	11/18/13	DWG SIZE	REV	
NOTICE - These drawings, specifications, or other data (1) are, and remain the property of Amphenol corp. (2) must be returned upon request; and (3) are confidential and not to be disclosed to any person other than those to whom they are given by Amphenol Corp. the furnishing of these drawings, specifications, or other data by Amphenol Corp., or to any other person to anyone for any purpose is not to be regarded by implication or otherwise in any manner licensing, granting rights to permitting such holder or any other person to manufacture, use or sell any product, process or design, patented or otherwise, that may in any way be related to or disclosed by said drawings, specifications, or other data.	FINISH	APPROVED	DATE	B	T	
		O. BARTHELMES	11/18/13			