

# NHD-0220WH-LTGH-JT#

## Character Liquid Crystal Display Module

|       |  |
|-------|--|
| NHD-  | Newhaven Display                                   |
| 0220- | 2 Lines x 20 Characters                            |
| WH-   | Display Type: Character                            |
| L-    | Model  |
| T-    | White LED Backlight                                |
| G-    | STN- Gray  |
| H-    | Transflective, 6:00 Optimal View, Wide Temperature |
| JT#-  | English and Japanese Standard Font                 |
|       | <b>RoHS Compliant</b>                              |

**Newhaven Display International, Inc.**

2661 Galvin Ct.

Elgin IL, 60124

Ph: 847-844-8795

Fax: 847-844-8796

[www.newhavendisplay.com](http://www.newhavendisplay.com)

[nhtech@newhavendisplay.com](mailto:nhtech@newhavendisplay.com)

[nhsales@newhavendisplay.com](mailto:nhsales@newhavendisplay.com)

## Document Revision History

| Revision | Date       | Description  | Changed by |
|----------|------------|--|------------|
| 0        | 10/21/2008 | Initial Release  | -          |
| 1        | 2/11/2010  | User Guide Reformat                                      | MC         |
| 2        | 6/3/2010   | Character code updated                                   | BE         |
| 3        | 3/1/2011   | Alternate controller information updated                 | AK         |
| 4        | 5/5/2011   | Electrical characteristics updated                       | AK         |
| 5        | 10/31/16   | Mechanical Drawing, Electrical and Optical Char. Updated | SB         |
| 6        | 12/8/16    | Supply Current Updated                                   | SB         |

## Functions and Features

- 2 lines x 20 characters
- Built-in controllers (ST7066U)
- +5.0V Power Supply
- 1/16 duty, 1/5 bias
- RoHS compliant

# Mechanical Drawing

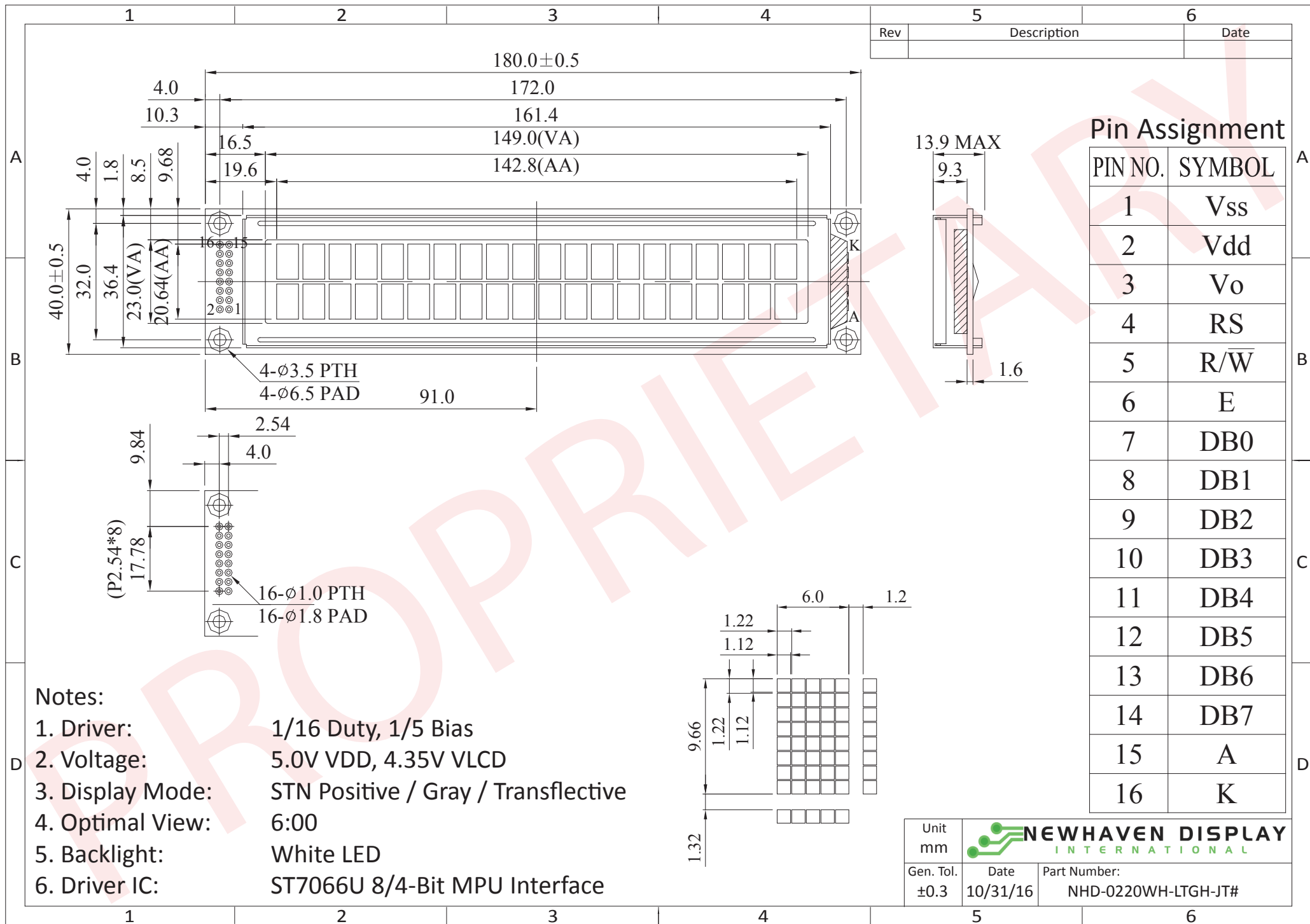

## Pin Description and Wiring Diagram

| Pin No. | Symbol  | External Connection | Function Description  |
|---------|---------|---------------------|---|
| 1       | Vss     | Power Supply        | Ground  |
| 2       | VDD     | Power Supply        | Supply Voltage for logic (+5.0)   |
| 3       | V0      | Power Supply        | Supply Voltage for contrast (approx. 0.65V)   |
| 4       | RS      | MPU                 | Register Select signal. RS=0: Command, RS=1: Data   |
| 5       | R/W     | MPU                 | Read/Write select signal, R/W=1: Read R/W:=0: Write   |
| 6       | E       | MPU                 | Operation Enable signal. Falling edge triggered.  |
| 7-10    | DB0-DB3 | MPU                 | Four low order bi-directional three-state data bus lines. These four are not used during 4-bit operation. |
| 11-14   | DB4-DB7 | MPU                 | Four high order bi-directional three-state data bus lines.  |
| 15      | LED+    | Power Supply        | Backlight Anode (+3.5)  |
| 16      | LED-    | Power Supply        | Backlight Cathode (Ground)  |

Recommended LCD connector: 2.54mm pitch pins

Backlight connector: --- Mates with: ---

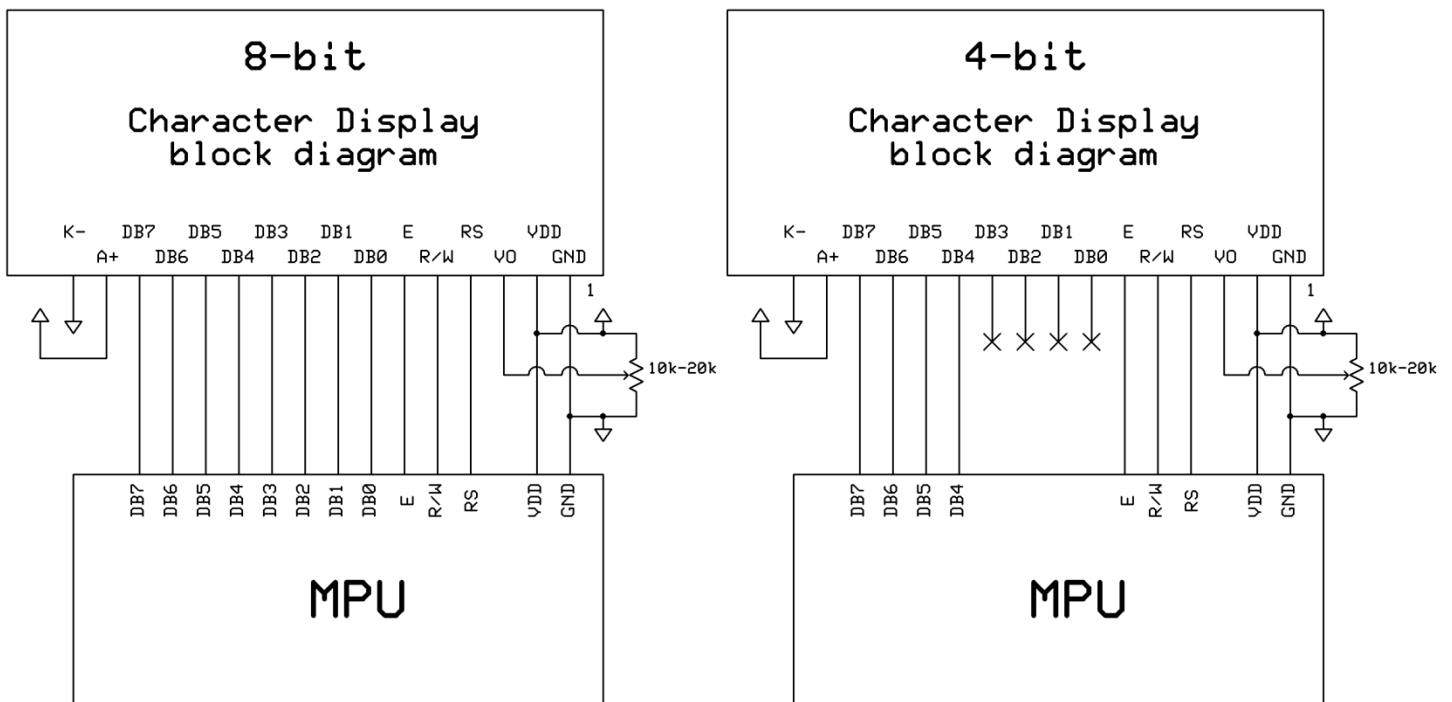

## Electrical Characteristics

| Item                        | Symbol    | Condition                                 | Min.    | Typ.   | Max. | Unit |
|-----------------------------|-----------|---|---------|--------|------|------|
| Operating Temperature Range | $T_{OP}$  | Absolute Max                              | -20     | -      | +70  | °C   |
| Storage Temperature Range   | $T_{ST}$  | Absolute Max                              | -30     | -      | +80  | °C   |
| Supply Voltage              | $V_{DD}$  | -   | 4.7     | 5.0    | 5.5  | V    |
| Supply Current              | $I_{DD}$  | $V_{DD} = 5.0V$<br>$T_{OP} = 25^{\circ}C$ | 0.5     | 1.8    | 3.5  | mA   |
| Supply for LCD (contrast)   | $V_{LCD}$ |   | 4.2     | 4.35   | 4.5  | V    |
| "H" Level input             | $V_{IH}$  | -   | 0.7 VDD | -      | VDD  | V    |
| "L" Level input             | $V_{IL}$  | -   | VSS     | -      | 0.6  | V    |
| "H" Level output            | $V_{OH}$  | -   | 3.9     | -      | VDD  | V    |
| "L" Level output            | $V_{OL}$  | -   | VSS     | -      | 0.4  | V    |
| Backlight Supply Voltage    | $V_{LED}$ | -   | 3.4     | 3.5    | 3.6  | V    |
| Backlight Supply Current    | $I_{LED}$ | $V_{LED} = 3.5V$                          | -       | 48     | 60   | mA   |
| Backlight Lifetime          | -         | $I_{LED} = 48\text{ mA}$                  | -       | 50,000 | -    | Hrs. |

## Optical Characteristics

| Item                   | Symbol | Condition              | Min. | Typ. | Max. | Unit |
|------------------------|--------|------------------------|------|------|------|------|
| Optimal Viewing Angles | Top    | $CR \geq 2$            | -    | 20   | -    | °    |
|                        | Bottom |                        | -    | 40   | -    | °    |
|                        | Left   |                        | -    | 30   | -    | °    |
|                        | Right  |                        | -    | 30   | -    | °    |
| Contrast Ratio         | CR     | -                      | -    | 2    | -    | -    |
| Response Time          | Rise   | $T_{OP} = 25^{\circ}C$ | -    | 150  | 200  | ms   |
|                        | Fall   |                        | -    | 150  | 200  | ms   |

## Controller Information

Built-in ST7066U controller.

Download specification at [http://www.newhavendisplay.com/app\\_notes/ST7066U.pdf](http://www.newhavendisplay.com/app_notes/ST7066U.pdf)

## DDRAM Address

|    |    |    |    |    |    |    |    |    |    |    |    |    |    |    |    |    |    |    |    |
|----|----|----|----|----|----|----|----|----|----|----|----|----|----|----|----|----|----|----|----|
| 1  | 2  | 3  | 4  | 5  | 6  | 7  | 8  | 9  | 10 | 11 | 12 | 13 | 14 | 15 | 16 | 17 | 18 | 19 | 20 |
| 00 | 01 | 02 | 03 | 04 | 05 | 06 | 07 | 08 | 09 | 0A | 0B | 0C | 0D | 0E | 0F | 10 | 11 | 12 | 13 |
| 40 | 41 | 42 | 43 | 44 | 45 | 46 | 47 | 48 | 49 | 4A | 4B | 4C | 4D | 4E | 4F | 50 | 51 | 52 | 53 |

## Table of Commands

| Instruction                | Instruction code |     |     |     |     |     |     |     |     |     | Description | Execution time (fosc=270 KHZ)  |        |
|----------------------------|------------------|-----|-----|-----|-----|-----|-----|-----|-----|-----|-------------|--|--------|
|                            | RS               | R/W | DB7 | DB6 | DB5 | DB4 | DB3 | DB2 | DB1 | DB0 |             |  |        |
| Clear Display              | 0                | 0   | 0   | 0   | 0   | 0   | 0   | 0   | 0   | 0   | 1           | Write "20H" to DDRAM and set DDRAM address to "00H" from AC  | 1.52ms |
| Return Home                | 0                | 0   | 0   | 0   | 0   | 0   | 0   | 0   | 0   | 1   | -           | Set DDRAM Address to "00H" from AC and return cursor to its original position if shifted. The contents of DDRAM are not changed. | 1.52ms |
| Entry mode Set             | 0                | 0   | 0   | 0   | 0   | 0   | 0   | 0   | 1   | I/D | SH          | Sets cursor move direction and specifies display shift. These parameters are performed during data write and read.               | 37μs   |
| Display ON/OFF control     | 0                | 0   | 0   | 0   | 0   | 0   | 0   | 1   | D   | C   | B           | D=1: Entire display on<br>C=1: Cursor on<br>B=1: Blinking cursor on  | 37μs   |
| Cursor or Display shift    | 0                | 0   | 0   | 0   | 0   | 0   | 1   | S/C | R/L | -   | -           | Sets cursor moving and display shift control bit, and the direction without changing DDRAM data.                                 | 37μs   |
| Function set               | 0                | 0   | 0   | 0   | 1   | DL  | N   | F   | -   | -   | -           | DL: Interface data is 8/4 bits<br>N: Number of lines is 2/1<br>F: Font size is 5x11/5x8  | 37μs   |
| Set CGRAM Address          | 0                | 0   | 0   | 1   | AC5 | AC4 | AC3 | AC2 | AC1 | AC0 |             | Set CGRAM address in address counter   | 37μs   |
| Set DDRAM Address          | 0                | 0   | 1   | AC6 | AC5 | AC4 | AC3 | AC2 | AC1 | AC0 |             | Set DDRAM address in address counter.  | 37μs   |
| Read busy Flag and Address | 0                | 1   | BF  | AC6 | AC5 | AC4 | AC3 | AC2 | AC1 | AC0 |             | Whether during internal operation or not can be known by reading BF. The contents of address counter can also be read.           | 0s     |
| Write data To Address      | 1                | 0   | D7  | D6  | D5  | D4  | D3  | D2  | D1  | D0  |             | Write data into internal RAM (DDRAM/CGRAM).  | 37μs   |
| Read data From RAM         | 1                | 1   | D7  | D6  | D5  | D4  | D3  | D2  | D1  | D0  |             | Read data from internal RAM (DDRAM/CGRAM).   | 37μs   |

# Timing Characteristics

## Writing data from MPU to ST7066U



| Write Mode (Writing data from MPU to ST7066U) |                       |                 |      |   |    |    |
|---|-----------------------|-----------------|------|---|----|----|
| $T_C$   | Enable Cycle Time     | Pin E           | 1200 | - | -  | ns |
| $T_{PW}$                                      | Enable Pulse Width    | Pin E           | 140  | - | -  | ns |
| $T_R, T_F$                                    | Enable Rise/Fall Time | Pin E           | -    | - | 25 | ns |
| $T_{AS}$                                      | Address Setup Time    | Pins: RS,RW,E   | 0    | - | -  | ns |
| $T_{AH}$                                      | Address Hold Time     | Pins: RS,RW,E   | 10   | - | -  | ns |
| $T_{DSW}$                                     | Data Setup Time       | Pins: DB0 - DB7 | 40   | - | -  | ns |
| $T_H$   | Data Hold Time        | Pins: DB0 - DB7 | 10   | - | -  | ns |

## Reading data from ST7066U to MPU



| Read Mode (Reading Data from ST7066U to MPU) |                       |                 |      |   |     |    |
|--|-----------------------|-----------------|------|---|-----|----|
| $T_C$  | Enable Cycle Time     | Pin E           | 1200 | - | -   | ns |
| $T_{PW}$                                     | Enable Pulse Width    | Pin E           | 140  | - | -   | ns |
| $T_{R,T_F}$                                  | Enable Rise/Fall Time | Pin E           | -    | - | 25  | ns |
| $T_{AS}$                                     | Address Setup Time    | Pins: RS,RW,E   | 0    | - | -   | ns |
| $T_{AH}$                                     | Address Hold Time     | Pins: RS,RW,E   | 10   | - | -   | ns |
| $T_{DDR}$                                    | Data Setup Time       | Pins: DB0 - DB7 | -    | - | 100 | ns |
| $T_H$  | Data Hold Time        | Pins: DB0 - DB7 | 10   | - | -   | ns |



# Built-in Font Table

| b7-b4<br>b3-b0 | 0000             | 0001 | 0010 | 0011 | 0100 | 0101 | 0110 | 0111 | 1000 | 1001 | 1010 | 1011 | 1100 | 1101 | 1110 | 1111 |   |
|----------------|------------------|------|------|------|------|------|------|------|------|------|------|------|------|------|------|------|---|
| 0000           | CG<br>RAM<br>(1) |      |      | 0    | a    | P    | ^    | F    |      |      |      | —    | 9    | 3    | o    | p    |   |
| 0001           | (2)              | !    | 1    | A    | Q    | a    | A    |      |      |      | e    | F    | 7    | G    | ä    | g    |   |
| 0010           | (3)              | "    | 2    | B    | R    | b    | r    |      |      |      | ”    | 4    | W    | X    | B    | e    |   |
| 0011           | (4)              | #    | 3    | C    | S    | c    | s    |      |      |      | „    | 9    | T    | E    | e    | *    |   |
| 0100           | (5)              | *    | 4    | D    | T    | d    | t    |      |      |      | „    | I    | f    | P    | u    | a    |   |
| 0101           | (6)              | z    | 5    | E    | U    | e    | u    |      |      |      | •    | †    | †    | 1    | o    | 0    |   |
| 0110           | (7)              | &    | 6    | F    | V    | f    | v    |      |      |      | ”    | 0    | 二    | 3    | p    | z    |   |
| 0111           | (8)              | ’    | 7    | G    | W    | g    | w    |      |      |      | ”    | †    | †    | 7    | g    | n    |   |
| 1000           | (1)              | <    | 8    | H    | X    | h    | x    |      |      |      | ”    | 9    | *    | U    | f    | z    |   |
| 1001           | (2)              | >    | 9    | I    | Y    | i    | y    |      |      |      | ”    | 9    | 7    | U    | ”    | y    |   |
| 1010           | (3)              | *    | :    | J    | Z    | j    | z    |      |      |      | ”    | z    | 0    | N    | V    | j    | z |
| 1011           | (4)              | +    | :    | K    | L    | k    | l    |      |      |      | ”    | †    | †    | E    | 0    | z    | n |
| 1100           | (5)              | ,    | <    | L    | †    | l    | l    |      |      |      | ”    | 9    | 7    | 7    | 9    | n    |   |
| 1101           | (6)              | —    | =    | M    | J    | m    | j    |      |      |      | ”    | z    | z    | z    | z    | z    |   |
| 1110           | (7)              | .    | >    | N    | ^    | n    | →    |      |      |      | ”    | z    | z    | z    | z    | n    |   |
| 1111           | (8)              | /    | ?    | O    | _    | o    | ←    |      |      |      | ”    | z    | z    | z    | z    | z    |   |

## Example Initialization Program

8-bit Initialization:

```

/*****/
void command(char i)
{
    P1 = i;                //put data on output Port
    D_I =0;                //D/I=LOW : send instruction
    R_W =0;                //R/W=LOW : Write
    E = 1;
    Delay(1);              //enable pulse width >= 300ns
    E = 0;                 //Clock enable: falling edge
}
/*****/
void write(char i)
{
    P1 = i;                //put data on output Port
    D_I =1;                //D/I=HIGH : send data
    R_W =0;                //R/W=LOW : Write
    E = 1;
    Delay(1);              //enable pulse width >= 300ns
    E = 0;                 //Clock enable: falling edge
}
/*****/
void init()
{
    E = 0;
    Delay(100);            //Wait >40 msec after power is applied
    command(0x30);         //command 0x30 = Wake up
    Delay(30);             //must wait 5ms, busy flag not available
    command(0x30);         //command 0x30 = Wake up #2
    Delay(10);             //must wait 160us, busy flag not available
    command(0x30);         //command 0x30 = Wake up #3
    Delay(10);             //must wait 160us, busy flag not available
    command(0x38);         //Function set: 8-bit/2-line
    command(0x10);         //Set cursor
    command(0x0c);         //Display ON; Cursor ON
    command(0x06);         //Entry mode set
}
/*****/
```

4-bit Initialization:

```

/*****/
void command(char i)
{
    P1 = i;                //put data on output Port
    D_I = 0;              //D/I=LOW : send instruction
    R_W = 0;              //R/W=LOW : Write
    Nybble();             //Send lower 4 bits
    i = i<<4;             //Shift over by 4 bits
    P1 = i;                //put data on output Port
    Nybble();             //Send upper 4 bits
}
/*****/
void write(char i)
{
    P1 = i;                //put data on output Port
    D_I = 1;              //D/I=HIGH : send data
    R_W = 0;              //R/W=LOW : Write
    Nybble();             //Clock lower 4 bits
    i = i<<4;             //Shift over by 4 bits
    P1 = i;                //put data on output Port
    Nybble();             //Clock upper 4 bits
}
/*****/
void Nybble()
{
    E = 1;
    Delay(1);              //enable pulse width >= 300ns
    E = 0;                 //Clock enable: falling edge
}
/*****/
void init()
{
    P1 = 0;
    P3 = 0;
    Delay(100);           //Wait >40 msec after power is applied
    P1 = 0x30;            //put 0x30 on the output port
    Delay(30);            //must wait 5ms, busy flag not available
    Nybble();             //command 0x30 = Wake up
    Delay(10);            //must wait 160us, busy flag not available
    Nybble();             //command 0x30 = Wake up #2
    Delay(10);            //must wait 160us, busy flag not available
    Nybble();             //command 0x30 = Wake up #3
    Delay(10);            //can check busy flag now instead of delay
    P1= 0x20;             //put 0x20 on the output port
    Nybble();             //Function set: 4-bit interface
    command(0x28);        //Function set: 4-bit/2-line
    command(0x10);        //Set cursor
    command(0x0F);        //Display ON; Blinking cursor
    command(0x06);        //Entry Mode set
}
/*****/

```

## Quality Information

| Test Item                             | Content of Test   | Test Condition   | Note |
|---------------------------------------|---|--|------|
| High Temperature storage              | Endurance test applying the high storage temperature for a long time.   | +80°C , 200hrs   | 2    |
| Low Temperature storage               | Endurance test applying the low storage temperature for a long time.  | -30°C , 200hrs   | 1,2  |
| High Temperature Operation            | Endurance test applying the electric stress (voltage & current) and the high thermal stress for a long time.                    | +70°C, 200hrs  | 2    |
| Low Temperature Operation             | Endurance test applying the electric stress (voltage & current) and the low thermal stress for a long time.                     | -20°C , 200hrs   | 1,2  |
| High Temperature / Humidity Operation | Endurance test applying the electric stress (voltage & current) and the high thermal with high humidity stress for a long time. | +60°C , 90% RH , 96hrs   | 1,2  |
| Thermal Shock resistance              | Endurance test applying the electric stress (voltage & current) during a cycle of low and high thermal stress.                  | -20°C,30min -> 25°C,5min -> 70°C,30min = 1 cycle<br>10 cycles                        |      |
| Vibration test                        | Endurance test applying vibration to simulate transportation and use.   | 10-55Hz , 1.5mm amplitude.<br>60 sec in each of 3 directions X,Y,Z<br>For 15 minutes | 3    |
| Static electricity test               | Endurance test applying electric static discharge.  | V <sub>s</sub> =±600V, R <sub>s</sub> =330Ω, C <sub>s</sub> =150pF<br>10 Times       |      |

**Note 1:** No condensation to be observed.

**Note 2:** Conducted after 4 hours of storage at 25°C, 0%RH.

**Note 3:** Test performed on product itself, not inside a container.

## Precautions for using LCDs/LCMs

See Precautions at [www.newhavendisplay.com/specs/precautions.pdf](http://www.newhavendisplay.com/specs/precautions.pdf)

## Warranty Information and Terms & Conditions

[http://www.newhavendisplay.com/index.php?main\\_page=terms](http://www.newhavendisplay.com/index.php?main_page=terms)