

MAXIM

MAX845 Evaluation Kit

Evaluates: MAX845

General Description

The MAX845 evaluation kit (EV kit) is an assembled and tested isolated 5V power supply that meets PCMCIA height requirements. Two demonstration circuits are provided: a 100mA circuit that uses an industry-standard 78L05 regulator, and a 40mA circuit that uses a low-cost zener shunt regulator. Both circuits consist of a MAX845 IC (in the μ MAX package), a low-profile transformer, a half-wave rectified voltage doubler, and a regulator.

Component List

DESIGNATION	QTY	DESCRIPTION
C11-C14, C21-C24	8	0.1 μ F ceramic 1206 capacitors
D11, D12	2	Motorola MBR0520L Schottky diodes
D21	1	Series-connected dual Schottky diodes Central Semiconductor CMPSH-3S
R22	1	51 Ω 1206 resistor
U11, U21	2	Maxim MAX845EUA
U12	1	78L05 in surface-mount 8-pin SOIC
T11, T21	2	1:1:1 low-profile transformer Halo TGM-010P3
Z21	1	5.1V, 5% zener in SOT-23 Central Semiconductor CMPZ5231B

Component Suppliers

SUPPLIER	PHONE	FAX
Central Semiconductor	(516) 435-1110	(516) 435-1824
Halo Electronics	(415) 969-7313	(415) 367-7158
Motorola	(602) 244-5303	(602) 244-4015

Features

- ◆ Isolated Power Supply
- ◆ Low Profile (for PCMCIA cards)

Ordering Information

PART	TEMP. RANGE	BOARD TYPE
MAX845EVKIT-MM	0°C to +70°C	Surface Mount

Quick Start

The MAX845 EV kit is fully assembled and tested. Follow the steps below to verify board operation. **Do not turn on the power supply until all connections are completed.** The circuit on the top half of the board can provide up to 100mA. The circuit on the lower half of the board can provide up to 40mA.

- 1) Connect a 4.5V to 5.5V supply to the pad marked +5V IN. The power-supply ground return connects to the GND pad.
- 2) Connect a voltmeter and load (if any) to the +5OUT pad. The load ground return connects to the ISO GND pad.
- 3) Turn on the power and verify that the output is 5V \pm 5%.
- 4) To evaluate shutdown, cut the trace connecting SD to GND and connect SD to V_{CC}.

MAX845 Evaluation Kit

Evaluates: MAX845

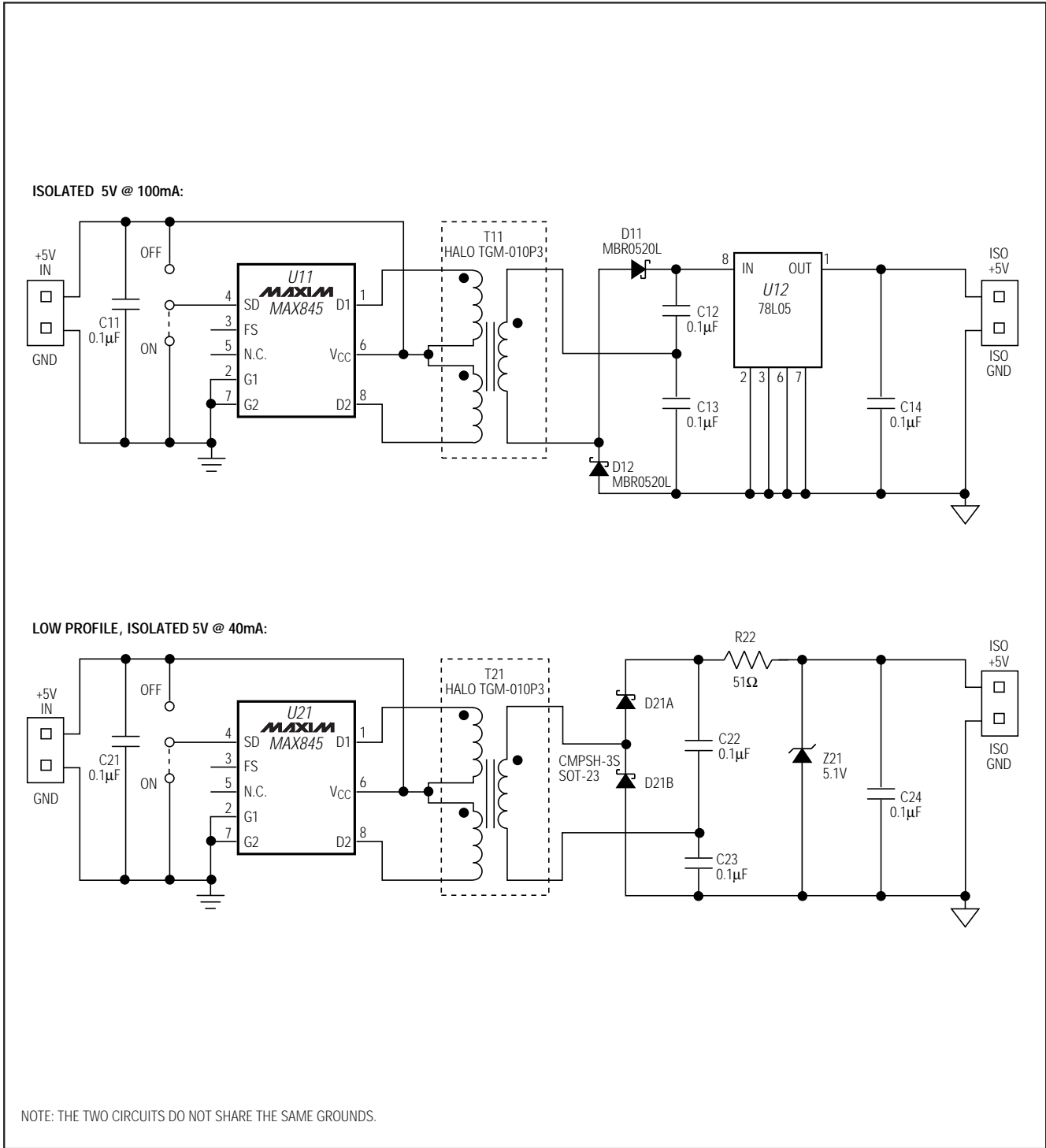

Figure 1. MAX845 EV Kit Schematic

MAX845 Evaluation Kit

Evaluates: MAX845

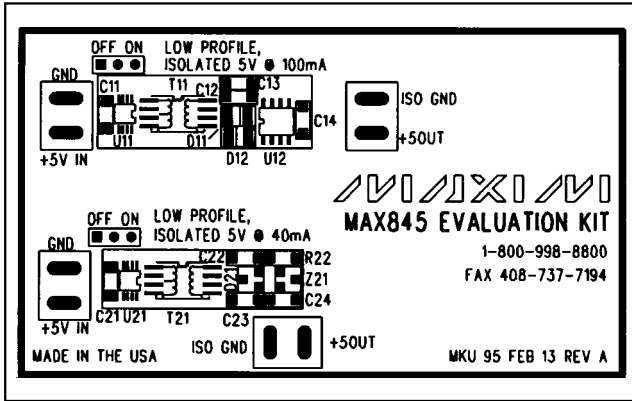

Figure 2. MAX845 EV Kit Component Placement Guide—Component Side

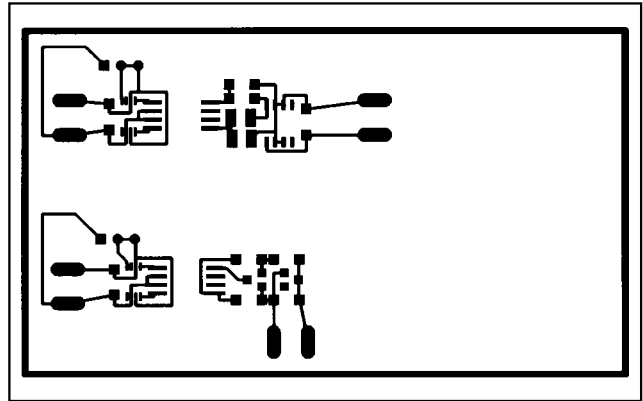

Figure 3. MAX845 EV Kit PC Board Layout—Component Side

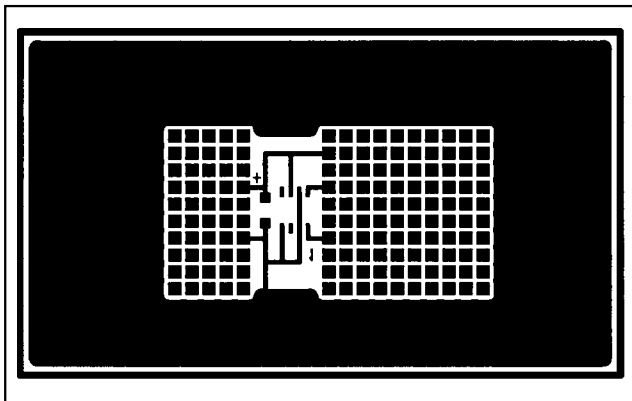

Figure 4. MAX845 EV Kit PC Board Layout—Solder Side

MAX845 Evaluation Kit

Evaluates: MAX845

NOTES

Maxim cannot assume responsibility for use of any circuitry other than circuitry entirely embodied in a Maxim product. No circuit patent licenses are implied. Maxim reserves the right to change the circuitry and specifications without notice at any time.

4 _____ Maxim Integrated Products, 120 San Gabriel Drive, Sunnyvale, CA 94086 408-737-7600

© 1997 Maxim Integrated Products

Printed USA

MAXIM is a registered trademark of Maxim Integrated Products.