

LOC	DIST	REVISIONS		
G	14	P	LTR	DESCRIPTION
		M2		REVISED PER ECO-11-004820
			DATE	OWN
			11MAR11	RK
				APVD
				HMR

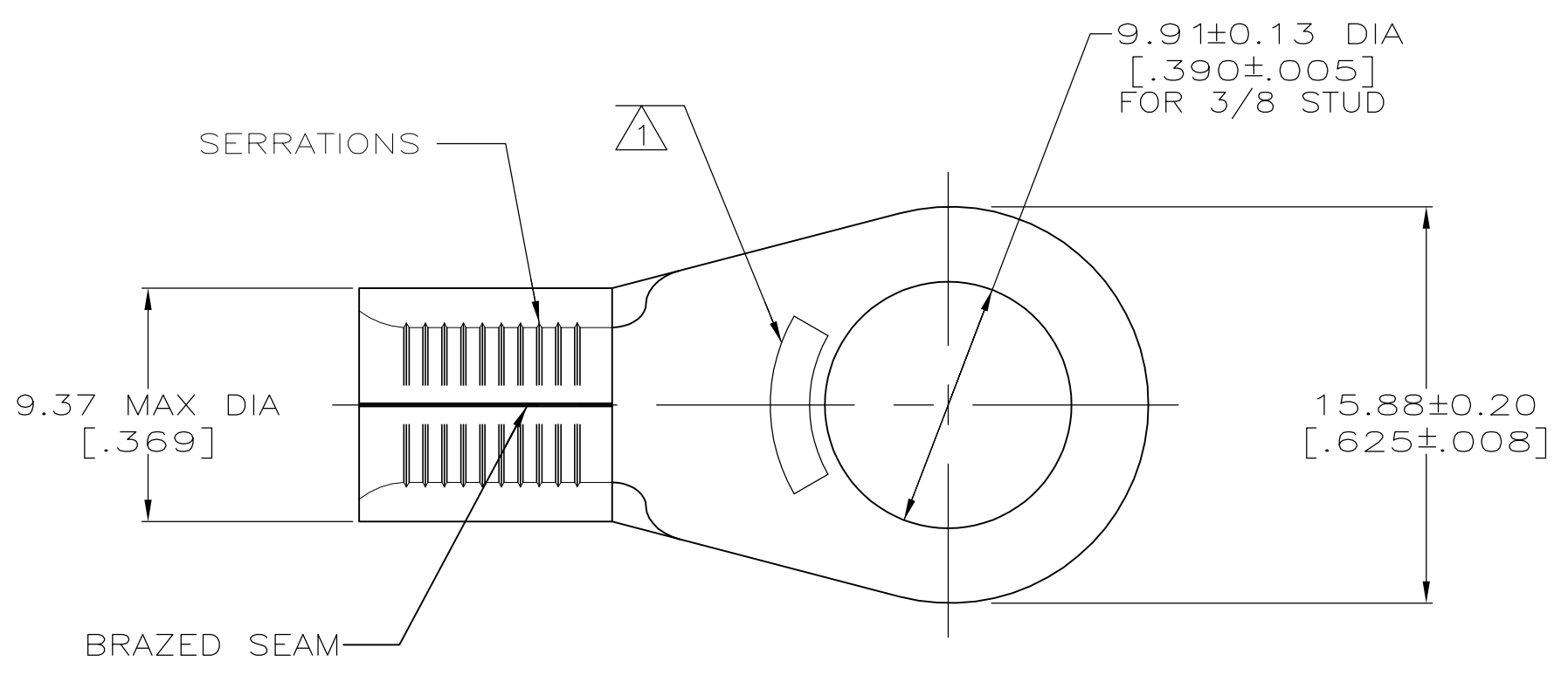

AMP WIRE RANGE	E13288 Listed
6 AWG SOLID OR STRANDED	6 AWG STRANDED
LR7189 Certified	MILITARY P/N AND CLASS
6 AWG SOLID OR STRANDED	MS 20659-110 CLASS 2 33467 ONLY

STAMP AMP 6* APPROX AS SHOWN

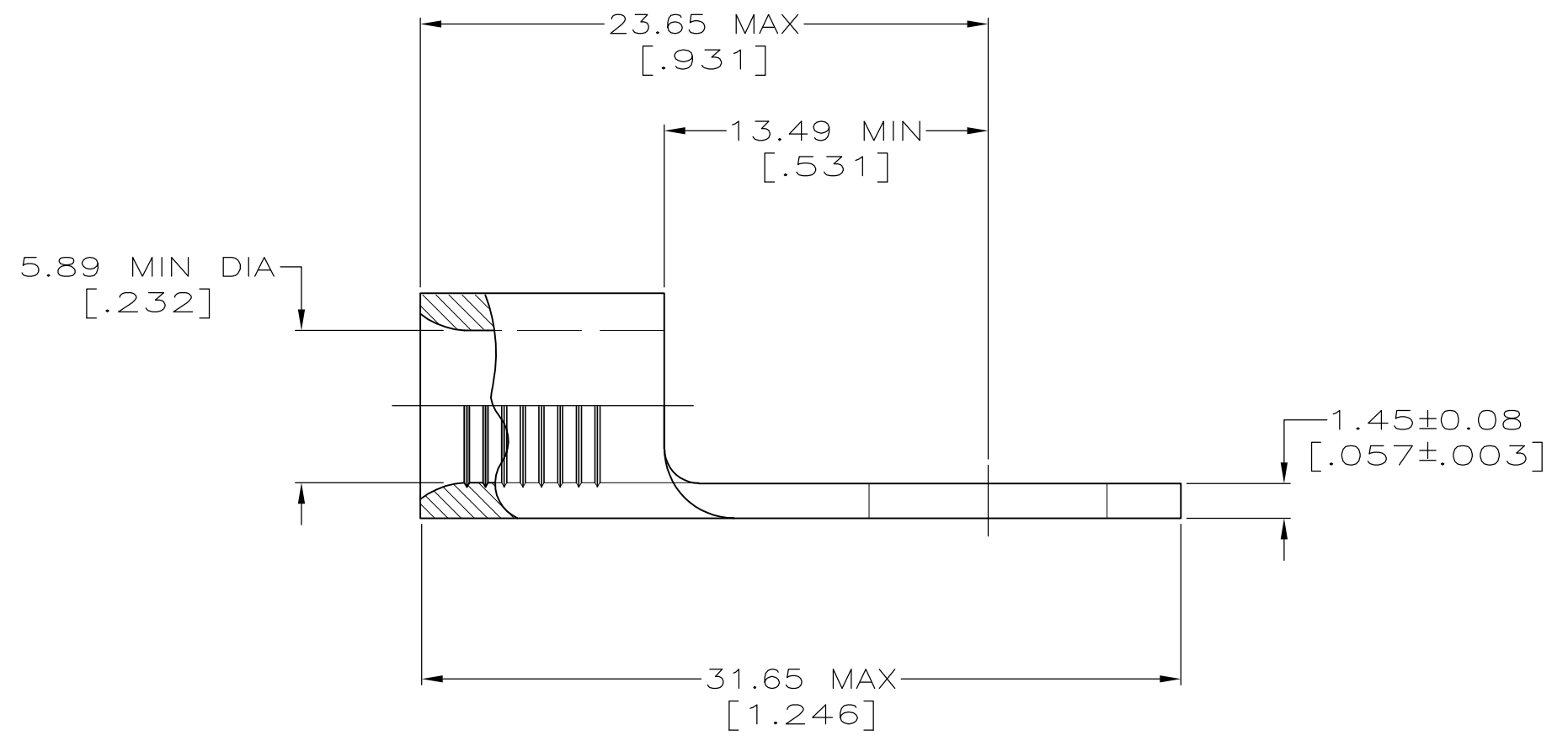

25	LOOSE PIECE, BAG	8-33467-5
25	LOOSE PIECE, BOX	8-33467-3
500	LOOSE PIECE, BOX	2-33467-4
750	TAPE MOUNTED	2-33467-3
-	LOOSE PIECE	33467
QUANTITY	PACKAGE TYPE	PART NO

AMP INCORPORATED CUSTOMER SERVICE SYSTEMS		MAX RECOMMENDED OPERATING TEMPERATURE: 170° C MAX
FOR ADDITIONAL PRODUCT INFORMATION OR COPIES OF DRAWINGS AND TECHNICAL DOCUMENTS	PRODUCT INFORMATION CENTER 1-800-522-6752	VOLTAGE RATING: NOT APPLICABLE
FOR APPLICATION TOOLING INFORMATION	TOOLING ASSISTANCE CENTER 1-800-722-1111	WIRE CROSS SECTIONAL AREA RANGE: 10.5-16.8mm ² [20,800-33,100] CIR MILS SOLID OR STRANDED
FOR ORDER ENTRY	1-800-526-5142	

THIS DRAWING IS A CONTROLLED DOCUMENT.		DWN TA BRINKMAN 3-24-93	TE Connectivity	
DIMENSIONS: mm [INCHES]		CHK DA PATTERSON 3-24-93	NAME DE MILLER	
TOLERANCES UNLESS OTHERWISE SPECIFIED:		APVD DE MILLER 3-24-93	PRODUCT SPEC	
0 PLC ± -		APPLICATION SPEC		
1 PLC ± -		WEIGHT		
2 PLC ± -		A2 00779 G-33467		
3 PLC ± -		CUSTOMER DRAWING		
4 PLC ± -		SCALE 4:1 SHEET 1 OF 1 REV M2		
ANGLES ± ± -		RESTRICTED TO		
FINISH		DRAWING NO		
COPPER PER ASTM B-152 ANNEALED		SIZE CAGE CODE		
TIN PLATE 0.0025±[.000100] MIN THK PER MIL-1-10727		DRAWING NO		